

# **International Journal of Sales, Retailing & Marketing**

## **CONTENTS:**

IMPACT OF CULTURAL AND INDIVIDUAL FACTORS ON CUSTOMER CHOICE STRATEGIES IN CHINA AND SOUTH KOREA: A STUDY IN THE MOBILE PHONE MARKET  
Lei Song, Gavin Jiayun Wu, Shan Feng and Alan J. Dubinsky

CUSTOMERS' OPINION AND RECEPTION OF INNOVATION IN RETAIL MARKET IN CROATIA  
Ivan Kovač, Marko Babić and Robert Bajkovec

UNDERSTANDING CONSUMERS' BEHAVIOUR TOWARDS ONLINE SHOPPING: A STUDY OF ONLINE SHOPPERS IN ANAMBRA STATE  
I.C Nwaizugbo and Ifeanyichukwu C.D

THE SUSTAINABLE DEVELOPMENT GOALS AND BUSINESS  
Peter Jones, David Hillier and Daphne Comfort

A COMPREHENSIVE PERSPECTIVE ON MEDICAL TOURISM CONTEXT AND A CREATION OF THE CONCEPTUAL FRAMEWORK  
Masoud Iajevardi

ETHICAL ISSUES AND SELLING: PERCEPTIONS OF MEN AND WOMEN  
Eileen Wall Mullen, Suzanne N. Cory and Guillermo Martinez

A COMPARISON OF HOME FURNISHINGS EXPENDITURES BY U.S. GENERATIONAL COHORT  
Katherine Annette Burns, Jessica Strubel and Michael B. Moody

**Vol. 5 No. 2 2016**

## EDITORS

**Professor Mirko Palić**, Ph.D. – Editor in Chief  
Marketing Department, Faculty of Economics and Business,  
University of Zagreb, Croatia  
[mpalic@efzg.hr](mailto:mpalic@efzg.hr)

**Professor Claudio Vignali**, Ph.D. – Editor for the UK  
Professor of Retail Marketing Management  
Leeds Metropolitan University, UK  
[c.vignali@leedsmet.ac.uk](mailto:c.vignali@leedsmet.ac.uk)

**Professor Bernd Hallier**, Ph.D. – Editor for Western Europe  
Managing Director of EHI Retail Institute  
President of The European Retail Academy  
[pasternak@ehi.org](mailto:pasternak@ehi.org)

**Professor John L. Stanton**, Ph.D. – Editor for the USA  
Professor and Chairman of the Food Marketing Department,  
St. Joseph's University, Philadelphia  
[jstanton123319@comcast.net](mailto:jstanton123319@comcast.net)

**Prof. Dr. Laetitia Radder**, D.Comm – Editor for Africa & Asia  
Professor of Marketing, Nelson Mandela Metropolitan University,  
South Africa, [Laetitia.Radder@nmmu.ac.za](mailto:Laetitia.Radder@nmmu.ac.za)

**www.ijssrm.com**

**ISSN 2045-810X**

International Journal of Sales, Retailing and Marketing is  
published by:

Access Press UK  
1 Hillside Gardens  
Darwen, Lancashire, BB3 2NJ  
United Kingdom

## EDITORIAL BOARD

Darko Tipuric Zagreb University Croatia	Management	dtipuric@efzg.hr
G.Orange Circle UK	Information systems	g.orange0153@gmail.com
Gianpaolo Vignali Manchester University UK	Fashion Marketing	gianpaolo.vignali@manchester.ac.uk
Daniela Ryding Manchester University UK	Fashion	Daniela.ryding@manchester.ac.uk
Bernd Britzelmaier Pforzheim University, D	Finance	bernd@britzelmaier.de
Tomasz Wisniewski Szczecin University Poland	Accounting and Finance	t.wisniewski.pl@gmail.com
Enrico Bonetti the University 2 Naples Italy	Services management	enrico.bonetti@unina2.it
George Lodorfos Leeds Met University UK	Strategic management	G.lodorfos@leedsmet.ac.uk
Alberto Mattiacci La Sapienza Rome Italy	Marketing and Business	alberto.mattiacci@uniroma1.it
Leo Dana The University of Montpellier France	Entrepreneurship	professordana@hotmail.com
Hans Rudiger Kaufmann University of Nicosia	SME	kaufmann.r@unic.ac.cy
Carmen.R. Santos University Leon Spain	European consumerism	Carmen.santos@unileon.es
Dolores Sanchez Bengoa Uni Vilnius	Cross Culture management	sanchezl@cytanet.com.cy
Michael Fass Uni of Glos. UK	Action Research	mfass@glos.AC.UK
Tomasz Bernat Uni of Szczecin Poland	Microeconomics	kontakt@tomaszbernat.pl
Mitsunori Hirogaki Kushimo University Japan	Japanese management	hirogaki@Kushiro-pu.ac.jp
Madalena Pereira Uni Beira Interior Portugal	European fashion	madaper@gmail.com
Iga Rudawska University of Szczecin Poland	Health marketing	igita@wneiz.pl
Carsten Barsch HDBW Germany	European Business	carsten.barsch@unvi.edu.ba
Edyta Rudawska Szczecin University Poland	Marketing development	edyta@rudawska.pl
Kreiso Znidar Prizma Zagreb Croatia	Marketing Research	kresimir.znidar@prizmacpi.hr
Martin Samy Leeds Met University UK	CSR	m.a.samy@leedsmet.ac.uk
Katarzyna Byrka-Kita Szczecin University, Pl	Finance in marketing	k.byrka-kita@wneiz.pl
S.Henderson Leeds Met University UK	Events marketing	s.henderson@leedsmet.ac.uk
Aftab Dean Leeds Met UK	Statistics	a.dean@leedsmet.ac.uk
Dominique Gerber Chur University Switzerland	Leisure and tourism	dominiquerolnad.gerber@htwchur.ch
Gianpaolo Basile University of Salerno Italy	Literature development	gibasile@unisa.it
Antonio Feraco Nan yang University Singapore	Development	Antonio.feraco@gmail.com
Barry Davies University of Gloucestershire UK	Research methods	bdavies@glos.ac.uk
Vitor Ambrosio ESHTe Portugal	Religious Tourism	vitor.ambrosio@eshte.pt
Razaq Raj Leeds Met University UK	Events and tourism man.	r.raj@leedsmet.ac.uk
Tahir Rashid Salford University UK	Islamic marketing	t.rashid@salford.ac.uk
Juergen Polke Gloucestershire University	Project development	polke@gbsco.com
Marija Tomašević Lišanin, Univ. of Zagreb	Sales	mtomasevic@efzg.hr
Charbel M. El Khoury, Holy Spirit Univ of Kaslik	Retailing	charbelmelkhoury@usek.edu.lb
Ravi Kandhadai	Marketing	drravikandhadai@gmail.com
Ivan Kovač, University of Zagreb	Retailing Management	ivankovac@efzg.hr

## Subscription Fees

2016 subscriptions are available in a number of major currencies.  
Exchange rates and prices will be held throughout 2016.

Subscription fees per volume are:

\$US 300  
£Stg 150  
\$Aus 370  
€ 210  
SFr 345  
¥ 33,740

Individual journal editions can be purchased at the following prices:

10 Journals @ £15 per journal  
20 Journals @ £10 per journal  
50 Journals @ £7 per journal

Subscription information is available from the Publishers at:

Access Press UK  
1 Hillside Gardens  
Darwen  
Lancashire  
BB3 2NJ UK  
+447815737243

## Reproduction Rights

The publishers of the International Journal of Sales, Retailing and Marketing have granted, free of charge, unlimited photocopying and other reproduction rights to subscribers, for teaching and study use within the subscribing organization. Authors may also photocopy or otherwise reproduce their particular case from The International Journal Sales, Retailing and Marketing, subject to an acknowledgement of publication and copyright details.



# Contents

<i>Editorial</i> .....	2
<i>IMPACT OF CULTURAL AND INDIVIDUAL FACTORS ON CUSTOMER CHOICE STRATEGIES IN CHINA AND SOUTH KOREA: A STUDY IN THE MOBILE PHONE MARKET</i> .....	3
Lei Song, Gavin Jiayun Wu, Shan Feng and Alan J. Dubinsky	
<i>CUSTOMERS' OPINION AND RECEPTION OF INNOVATION IN RETAIL MARKET IN CROATIA</i> .....	17
Ivan Kovač, Marko Babić and Robert Bajkovec	
<i>UNDERSTANDING CONSUMERS' BEHAVIOUR TOWARDS ONLINE SHOPPING: A STUDY OF ONLINE SHOPPERS IN ANAMBRA STATE</i> .....	28
I.C Nwaizugbo and Ifeanyichukwu C.D	
<i>THE SUSTAINABLE DEVELOPMENT GOALS AND BUSINESS</i> .....	38
Peter Jones, David Hillier and Daphne Comfort	
<i>A COMPREHENSIVE PERSPECTIVE ON MEDICAL TOURISM CONTEXT AND A CREATION OF THE CONCEPTUAL FRAMEWORK</i> .....	49
Masoud lajevardi	
<i>ETHICAL ISSUES AND SELLING: PERCEPTIONS OF MEN AND WOMEN</i> .....	74
Eileen Wall Mullen, Suzanne N. Cory and Guillermo Martinez	
<i>A COMPARISON OF HOME FURNISHINGS EXPENDITURES BY U.S. GENERATIONAL COHORT</i> .....	88
Katherine Annette Burnsed, Jessica Strubel and Michael B. Moody	

## Editorial



The current issue of the International Journal of Sales, Retail and Marketing is once more dedicated to the best research papers from the area of retailing, sales and marketing. In this issue we are proud to present seven original research papers from the U.S.A., Great Britain, Iran, Nigeria and Croatia. The contributing authors published several interesting researches from the area of customer behaviour, customer

choice strategies, innovations in FMCG retailing, sustainable development, ethical issues in selling, expenditures in U.S. by generational cohorts and finally about perspectives of medical tourism in Iran.

The profile of contributors to the Journal ranges from well-known established professors to young and promising doctoral students whose time is yet to come.

Thank you for taking interest in publishing and reading ***The International Journal of Sales, Retailing and Marketing***. We hope it will be a valuable help in your professional and academic advancement.

*Editor,*

A handwritten signature in blue ink that reads "Mirko Palić".

*Mirko Palić, Ph.D.*



# IMPACT OF CULTURAL AND INDIVIDUAL FACTORS ON CUSTOMER CHOICE STRATEGIES IN CHINA AND SOUTH KOREA: A STUDY IN THE MOBILE PHONE MARKET

Lei Song, Gavin Jiayun Wu, Shan Feng and Alan J. Dubinsky

## **Abstract**

*Understanding customers' choice strategies is important in order for marketing managers to develop and implement marketing programs directed at improving customer satisfaction. Prior research on customer choice strategies has mainly focused on decisions related to different product attributes or purchasing situations in Western cultures. Little research, however, has focused on how cultural and individual factors affect customer choice strategies within an East Asian context. This research fills this gap by investigating the adoption of choice strategies in China and South Korea. It examines the extent to which ethnocentrism, emotion, purchasing experience, imitation, and patience influence which choice strategies customers adopt: lexicographic, elimination-by-aspects, or weighted additive. Results provide practical implications on how multi-national companies might adjust their strategies in Chinese and South Korean cultures.*

**Keywords:** *Customer choice strategies, culture, China, South Korea, East Asia, mobile phone*

## **Introduction**

The electronics communications market in East Asia has grown rapidly. As of November 2012, China had 1.104 billion mobile phone users, an increase of nearly 118 million people during the first eleven months of 2012. As of April 2015, Chinese mobile phone users reached 1.29 billion (TechinAsia, 2015). Despite the substantial increase in mobile phone users, multinational companies (MNCs) face considerable barriers in

attracting local customers from certain cultures (Bhattacharya & Michael, 2008). For example, in 2015, the market share of Apple smartphones in China shrank to 14.3%, whereas Chinese competitors' Xiaomi and Huawei smartphones' market share increased to 14.9% and 14.3%, respectively. On the other hand, by the end of 2014, the market share of Apple smartphones in South Korea increased to 33% (Counterpoint Research, 2015).

Given the foregoing market share vicissitudes in the East Asian mobile phone industry, international marketers need information to facilitate their entry into and continued success in East Asian market. Cultural and individual factors have been found to impact long-term orientation in buyer-seller relationships (Cannon et al., 2010), affect advertising perceptions

**Lei Song** is Assistant Professor, School of Business, Stockton University, Galloway, New Jersey, USA

**Gavin Jiayun Wu** is Assistant Professor, College of Business Administration, Savannah State University, Savannah, Georgia, USA

**Shan Feng** is Assistant Professor, Department of Marketing and Management Sciences, William Paterson University, Wayne, New Jersey, USA

**Alan J. Dubinsky** is Professor Emeritus at Purdue University, West Lafayette, IN 47907, USA. E-mail: [dubinsky@purdue.edu](mailto:dubinsky@purdue.edu)

(Pollay et al., 1990), one's need for uniqueness (Kim & Markus, 1999), and influence emotional responses and sensory perceptions (Curtis & Bharucha, 2009). Moreover, these factors also influence how individuals process information (Kastanakis & Voyer, 2014). Accordingly, understanding cultural and individual factors that affect Chinese and South Korean customers' *choice strategies* when purchasing mobile phones might help MNCs improve the design and implementation of their marketing strategies.

Notwithstanding the increased interest in investigating East Asia, prior research in customer *choice strategies* has focused primarily on the U.S. culture or on comparing between Eastern and Western cultures (Alba & Marmorstein, 1987; Fader & MacAlister, 1990; Swait & Adamowicz, 2001; Su, 2007). Little attention has been given specifically to reconnoitering customer choice strategies within the East Asian context (Kim et al., 2002). Furthermore, because China and South Korea's economic growth are among the fastest in the region (CIA, 2015), understanding cultural and individual factors affecting customers seems essential and merits empirical attention.

Customers in China and South Korea were the focus of the current research effort due to their similarity as well as differences. Both countries represent rapidly growing customer markets in Asia (Kim et al., 2002; Whang et al., 2016). China and South Korea also have somewhat similar cultures, as they are both affected by Confucian principles (Zane, 1992; Kim et al., 2007).

Meanwhile, both countries differ in several aspects. Although the two countries may have similar values, they are different in retail market development owing to different paths taken to free market economies (Kim et al., 2002). Moreover, foreign investors view China as the market with a giant population, whereas South Korea is perceived as a market with a wealthy customer base (Frank, 2001; Terpstra et al., 2012).

The foregoing disquisition led to the current investigation. In particular, examination of Chinese and Korean customers' choice strategies—elimination-by-aspects (EBA), lexicographic, and weighted-additive—vis-à-vis ethnocentrism, emotion, purchasing experience, imitation, and patience was explored. According to Zhang (2004), these factors have been identified as playing a major role in customer choice strategies in East Asia. Although they have been considered in prior investigations, this study extends extant germane work by identifying specific factors that affect adoption of each choice strategy.

The primary goals for this research are threefold: (1) to investigate how cultural and individual factors affect Chinese and South Korean customers' purchase decisions, (2) to uncover associations between cultural and individual factors and customer choice strategies, and (3) to provide implications for companies in the development and execution of their strategies so as to better serve customers.

## **Theoretical Framework and Hypothesis Development**

### **Customer Choice Strategies**

Choice strategies refer to customers' psychological method in selecting the most appropriate offering (product or service) from an array of alternatives (Bettman et al., 1998). Over 300 years ago, Nicholas Bernoulli, John von Neumann, and Oskar Morgenstern pioneered the field (Richarme, 2005). Their early work approached the customer decision-making process exclusively from an economic perspective, asserting that individuals are rational beings concerned solely with their own self-interest and preservation (Loudon et al., 1993).

However, recent theories transcend this "rational being perspective" to argue that multiple forces, objectives, and characteristics influence decision making (e.g., Armstrong &



Kotler, 2006; Bakewell & Mitchell, 2003; Carpenter & Fairhurst, 2005; Meyer & Rowan, 1991; Zaltman, 2003). For example, in the 1950s customer behavior began to reflect the notion of modern marketing to explore a wider range of holistic activities that affect customer decisions (Kasper et al., 2010); most prior research has focused on developing choice strategies and investigating situational and environmental factors that influence them (e.g., Manrai & Sinha, 1989; Simon, 1955; Tversky, 1972). For instance, Swait and Adamowicz (2001) outlined a theoretical model that simultaneously considers task complexity, customer effort, ability to choose, and choice; Lynch and Srull (1982) averred, though, that memory and attention processes in choice strategy may occur below the level of consciousness.

Particularly related to the present study's theoretical framework, previous researchers have also identified various ways in which customers make product choices. For example, Bettman (1979) suggested that depending on whether or not weakness in one product attribute can be offset by strength in another, customers will process product information in two different ways: *compensatory* and *non-compensatory*. Below, differences between compensatory and non-compensatory choice strategies are discussed.

### **Compensatory vs. Non-Compensatory Choice Strategies**

*Compensatory strategies* entail customers' examining a weakness in one attribute while considering a strength in another (Bettman, 1979). Simple-additive and weighted-additive (which require high involvement) are two major types of compensatory choice strategies. With a *simple-additive strategy*, customers add the number of times each alternative is favorably judged in terms of all attributes, and the alternative with the highest number of favorable judgments is chosen (Costa & Vincke, 1995; Pachur & Forrer, 2013). Customers adopting a

*weighted-additive strategy* take into account the salience of relevant evaluative criteria in addition to whether an alternative is favorable on those criteria (Pachur & Forrer, 2013). This strategy is similar to multi-attribute attitude models (e.g., Ajzen & Fishbein, 1980; Fishbein, 1963; Fishbein & Ajzen, 1975).

*Non-compensatory strategies* entail identifying weakness in one product attribute that cannot be offset by the strength in another product attribute (Bettman, 1979). The literature has identified three major types of non-compensatory choice strategies: lexicographic, EBA, and conjunctive. *Lexicographic* is a low-involvement strategy in which the customer compares products or brands on the most important attribute; the alternative that is perceived as superior on that single attribute is selected (Kohli & Jedidi, 2007). For example, Yee et al. (2007) reported that when evaluating smartphones, approximately two-thirds of subjects used lexicographic rules.

Customers following an *EBA strategy*—which requires medium involvement (Bettman, 1979)—evaluate brands on all important attributes and impose a cut-off value for each attribute. Products are assayed on each attribute one at a time and eliminated once they fail to meet the cut-off value for a given attribute (Gilbride & Allenby, 2006; Tversky, 1972).

Different from lexicographic and EBA strategies, a *conjunctive strategy* entails establishing a cut-off value for all attributes and then comparing each product against the set of imposed cut-off values. A product will be chosen only if it meets or exceeds the cut-off value for all attributes (Jedidi & Kohli, 2005; Yee et al., 2007).

The current research investigates lexicographic, EBA, and weighted additive choice strategies as they are among the most frequently adopted choice strategies among East Asian customers (Pachur & Forrer, 2013).

### Impact of Cultural and Individual Factors on Customer Choice Strategies

Marketing scholars have proposed that customer choice strategies be examined in light of the following five cultural and individual antecedents: ethnocentrism, emotions, purchasing experience, imitation, and patience (e.g., Zhang, 2004). Based on extant work, a discussion of how each of these factors affects Chinese and South Korean customers' choice strategies is presented.

**Ethnocentrism.** Ethnocentrism represents one's preference for his/her own group over other groups (Sumner, 1906). Shimp and Sharma (1987) defined ethnocentrism as customers' tendency to avoid purchasing foreign products owing to potential economic losses it would cause for their own country. Ethnocentric customers tend to purchase domestic products, although the quality of foreign products may appear better to them (Supphellen & Rittenburg, 2001). In contrast, less ethnocentric customers evaluate products based on attributes and merits without considering the country of manufacture (Shimp & Sharma, 1987). Other research has also shown that ethnocentric customers would purchase their own country's products more frequently than less ethnocentric ones (Tsai et al., 2013; Zhang, 2004).

Ethnocentrism affects which choice strategies customers' adopt. Researchers have found that customer attitudes and purchase intention toward foreign products vary across individuals (Ahmad & Richard, 2014; Carpenter et al., 2013; Supphellen & Rittenburg, 2001; Watson & Wright, 2000; Yoo & Danthu, 2005). Studies also suggest that individual customers from certain cultures—such as South Korea and China—tend to have less favorable attitudes toward foreign brands due to high ethnocentrism (Balabanis & Diamantopoulos, 2004; Balabanis & Diamantopoulos, 2008; Sharma et al., 1995). Accordingly, when making choices among an assortment of brands, ethnocentric customers seemingly will eliminate

foreign-branded products first, while those who are lower in ethnocentricity are less likely to do so. Instead, such individuals may well focus more on using product attributes (e.g., color, function) rather than country of origin to make product decisions (Tsai et al., 2013). Because customers adopting an EBA strategy eliminate products by attributes, less ethnocentric customers are more likely to adopt an EBA strategy than customers who are more ethnocentric.

**Hypothesis 1:** *Chinese and South Korean individuals with higher ethnocentrism are less likely to adopt an EBA choice strategy than those with lower ethnocentrism.*

Emotion affects customer behavior. For example, Greenleaf and Lehmann (1995) found that emotions can delay customers' choice-making process. Kemp and Komp (2011) ascertained that customers tend to regulate emotions by consuming hedonic products. Winterich and Haws (2011) discerned that positive emotions increase self-control (also see Bee & Madrigal, 2013; Lerner & Keltner, 2000; Luchs et al., 2012). Furthermore, Araña & León (2009) revealed that emotions can partially explain a customer's decision to choose either a compensatory or non-compensatory decision strategy. Specifically, as emotional intensity increases, probability of choosing a non-compensatory strategy increases.

Emotion differences among individuals should affect customers' adoption of choice strategies. Zhang (2004) suggested that emotionally more intense customers make faster decisions than emotionally less intense customers. Also, empirical work has found that emotionally-intense customers are more likely to make decisions by focusing on a single attribute than their less emotionally-intense counterparts. Moreover, customers who make more rapid decisions are less likely to be highly involved (Velásquez, 1998). Thus, more emotionally intense customers—compared with

their emotionally less intense counterparts—are more likely to choose a lexicographic strategy, as it requires less involvement and keener focus on a single attribute when making product decisions.

**Hypothesis 2:** *Chinese and South Korean individuals with higher emotional intensity are more likely to adopt a lexicographic choice strategy than those with lower emotional intensity.*

**Purchasing Experience.** Research shows that purchasing experience influences customers' adoption of choice strategies. When customers experience uncertainty about making a purchase decision, they draw on their "information set," which is composed of past purchasing experiences (Alba & Marmorstein, 1987; Erdem & Keane, 1996). Researchers have demonstrated the importance of understanding this process to aid in predicting which decision-making style a customer will adopt (Freimer & Horsky, 2008; van der Merwe et al., 210).

Individual differences in purchasing experience should affect customers' adoption of choice strategies. Hoyer (1984) found that individuals with more product purchasing experience are less likely to be highly involved in purchasing decisions. This is because repetition (e.g., repeated purchasing) reduces the amount of cognitive effort involved (Lavie, 2005). Zhang (2004) ascertained that customers' involvement in purchasing decisions affects the choice strategies they adopt. Thus, customers who have more purchasing experience are more likely to adopt low-involvement choice strategies, such as a lexicographic strategy.

**Hypothesis 3:** *Chinese and South Korean individuals with more purchasing experience are more likely to adopt a lexicographic choice strategy than those with less purchasing experience.*

Imitation can have a significant impact on customer choice strategies. Katsikopoulos (2011) showed that use of a lexicographic choice strategy relies heavily on core human capacities (e.g., imitation, recall, recognition). We use herd literature to understand customers' mimetic behavior. Herd literature posits that people may discount their own beliefs and imitate others when making decisions (Sun, 2009). Herd behavior has been documented in many academic fields, including technology (Sun, 2013), financial markets (Bernhardt et al., 2006; Bikhchandani & Sharma, 2001), psychology (Belz et al., 2013; Stallen et al., 2012), medical (Chapman et al., 2012), and purchase decisions (Chen, 2008; Chen, 2011).

Customers' imitation behaviors should affect their adoption of choice strategies. Herd behaviors literature has shown that imitating other people when purchasing products allows them to be less involved in the decision-making process, because imitators do not need to go through the mental process that leads to the final purchasing decision (Katsikopoulos, 2011). Thus, imitators are less likely to be highly involved in choosing cellphones, and are less likely to adopt choice strategies that require high involvements. Also, Lavie (2005) suggest that when customers are less involved in the purchase of products, they would be more likely to adopt low-involvement strategies, such as lexicographic. Thus,

**Hypothesis 4:** *Chinese and South Korean individuals who are more likely to imitate others are more likely to adopt a lexicographic choice strategy than those less likely to imitate others.*

**Patience.** Individuals have different levels of patience when making purchasing decisions. Indeed, Fan and Xiao (1998) noted that certain customers are more patient than others when making product decisions. Zhang (2004) has shown that individuals with more patience are more likely to be highly involved

and spend more time during the purchase decision-making process. Highly involved customers are more likely to adopt choice strategies that require high involvement (Katsikopoulos, 2011). Therefore, more patient customers are more likely to choose choice strategies that require high involvement and more time spent. Because the weighted additive strategy requires high involvement and is more time consuming (Bettman et al., 1998), patient

customers are more likely to employ this strategy.

**Hypothesis 5:** *Chinese and South Korean individuals who are more patient when make a purchase decision are more likely to adopt a weighted-additive choice strategy than those who are less patient when making a purchase decision.*

## Methodology

### Sample and Measurement

**Sample.** To test the study's proposed model and hypotheses, data were collected from college students in China and South Korea. They were chosen as the sampling frame for several reasons. First, college students in China and South Korea are more advanced in the customer socialization process and have a greater familiarity with market exchange than other generations (Fan & Xiao, 1998). Second, they are the first cohorts of young individuals raised entirely in the digital age, thus earning the titles of "digital natives" and "hyper-connected" (Lepp et al., 2013). Moreover, 96% of undergraduate and 99% of graduate students in these two countries own a cell phone compared with 89% of non-students and 82% of adults (Fox, 2011). Because mobile phone use is so prevalent among college students, this sampling frame is a logical starting point for examining Chinese and South Korean customers' choice strategies when purchasing such products. In all, 208 valid questionnaires were collected, including 110 from South Koreans (46 females and 64 males) and 98 (40 female and 58 male) from Chinese. Approximately 70% were between 22 and 27 years old.

**Measurement.** A survey of Chinese and South Korean respondents was administered in universities in Jinan, Shandong province, China and in Seoul, South Korea, respectively. A questionnaire was created in Korean and then translated into Chinese. The questionnaire was

also back translated into Korean by a bilingual translator to ensure consistency (Cha et al., 2007).

As part of the survey procedure, participants were first introduced to the purpose of the study; then they completed the questionnaire. In the questionnaire, they first completed items pertaining to ethnocentrism, emotion, purchasing experience, imitation, and patience. These factors were assessed using items from the work of Zhang (2004). Respondents utilized a 5-point Likert scale when responding to those items (1 = strongly disagree, 5 = strongly agree). Sample items for each factor are noted below.

Ethnocentrism: "I don't buy the brand of other countries, because this is bad for our country's economy."

Emotion: "I consider myself as being more emotional than the average person."

Purchasing experience: "How many times have you purchased cell phones before?"

Imitation: "I have bought a cell phone because a person I know bought the cell phone."

Patience: "I consider myself more patient than the average person."

Subsequent to addressing the foregoing factors, respondents next rates "Yes" or "No" to their choice of strategies, including lexicographic, EBA, and weighted-additive. Participants also provided demographic information. They were

debriefed and thanked upon completion of the survey.

**Analysis and Results**

**Proposed Model**

Ethnocentrism, experience, emotion, imitation, and patience were independent variables in the proposed model. Three choice strategies—lexicographic, EBA, and weighted-additive—were adopted as dependent variables.

A model was created to show the relationships between the independent and dependent variables. X<sub>1</sub>, X<sub>2</sub>, etc., were utilized to denote cultural and individual variables (e.g., ethnocentrism), and Y to represent customers’ chosen decision-making strategy (e.g., EBA). βs were adopted to represent effects of each

variable on customer choice strategies. Thus, the following model was used to examine customer choice strategies:

$$Y = \beta_0 + \beta_1 X_1 + \beta_2 X_2 + \beta_3 X_3 + \beta_4 X_4 + \beta_5 X_5 + \epsilon$$

- X<sub>1</sub>: Experience
- X<sub>2</sub>: Ethnocentrism
- X<sub>3</sub>: Emotion
- X<sub>4</sub>: Imitation
- X<sub>5</sub>: Patience
- βn: Model Parameters
- ε: Error

The Y-variable contained the three strategies, Lexicographic, EBA, and Weighted-additive, as noted below.

$$Y_{lex} = \begin{cases} 1 & \text{if a participant chooses "Yes" to a lexicographic strategy} \\ 0 & \text{if a participant chooses "No" to a lexicographic strategy} \end{cases}$$

$$Y_{eba} = \begin{cases} 1 & \text{if a participant chooses "Yes" to an EBA strategy} \\ 0 & \text{if a participant chooses "No" to an EBA strategy} \end{cases}$$

$$Y_{wa} = \begin{cases} 1 & \text{if a participant chooses "Yes" to a weighted additive strategy} \\ 0 & \text{if a participant chooses "No" to a weighted additive strategy} \end{cases}$$

Three regressions were run on each dependent variable separately. Shown in Table 1 are findings for the first regression with the lexicographic strategy as the dependent variable. Portrayed in Table 2 are results for the second regression with the EBA strategy as the

dependent variable. Depicted in Table 3 are findings for the third regression with the weighted-additive strategy as the dependent variable.

**Table 1:** Summary of Findings with Lexicographic as the Dependent Variable (Y)

Independent Variables (X)	β Value	Std. Dev.	T-Value	P-Value	# Tails
Experience	0.151	0.062	2.435483871	0.015081	2
Ethnocentrism	0.04	0.074	0.540540541	0.588969	2
Imitation	0.183	0.085	2.152941176	0.031610	2
Patience	0.088	0.137	0.642335766	0.520832	2
Emotion	0.229	0.123	1.861788618	0.062985	2

**Table 2:** Summary of Findings with Elimination by Aspects as the Dependent Variable (Y)

Independent Variables (X)	$\beta$ Value	Std. Dev.	T-Value	P-Value	#Tails
Experience	0.109	0.06	1.816666667	0.069628	2
Ethnocentrism	0.263	0.078	3.371794872	0.000781	2
Imitation	0.109	0.065	1.676923077	0.093933	2
Patience	0.131	0.332	0.394578313	0.693255	2
Emotion	0.14	0.067	2.089552239	0.036961	2

**Table 3:** Summary of Findings with Weighted-Additive as the Dependent Variable (Y)

Independent Variables (X)	$\beta$ Value	Std. Dev.	T-Value	P-Value	# Tails
Experience	-0.368	0.067	5.492537313	5.26E-08	2
Ethnocentrism	0.182	0.132	1.378787879	0.168331	2
Imitation	-0.289	0.072	4.013888889	6.51E-05	2
Patience	0.777	0.13	5.976923077	3.37E-09	2
Emotion	1.373	0.18	7.627777778	6.53E-14	2

### Findings

Hypothesis 1 asserted that Chinese and South Korean individuals with higher ethnocentrism would be less likely to adopt an EBA choice strategy. As shown in Tables 2, however, there is a significant positive relationship between ethnocentrism and adoption of an EBA choice strategy ( $\beta = .26, p < .001$ ), indicating that those with higher ethnocentrism are more likely to adopt an EBA choice strategy. As a result, hypothesis 1 is rejected.

Hypothesis 2 proposed that Chinese and South Korean individuals with high emotional intensity would be more likely to adopt a lexicographic choice strategy. As shown in Table 1, there is a marginally significant positive relationship between emotion and adoption of lexicographic choice strategy ( $\beta = .23, p < .10$ ). Therefore, hypothesis 2 was confirmed.

Hypothesis 3 averred that Chinese and South Korean individuals with more purchasing experience would be more likely to adopt a lexicographic choice strategy. There is a significant positive relationship between purchasing experience and the adoption of a lexicographic choice strategy ( $\beta = .15, p < .05$ ;

see Table 1). Thus, hypothesis 3 received support.

Hypothesis 4 argued that Chinese and South Korean individuals who are more likely to imitate others would be more likely to adopt a lexicographic choice strategy. As shown in Table 1, there is a significant positive relationship between imitation and adoption of a lexicographic choice strategy ( $\beta = .18, p < .05$ ). As such, hypothesis 4 was supported.

Hypothesis 5 proffered that Chinese and South Korean individuals who are more patient would be more likely to adopt a weighted-additive choice strategy. As shown in Table 3, there is a significant positive relationship between patience and the adoption of a weighted additive choice strategy ( $\beta = .78, p < .001$ ). Thus, hypothesis 5 was confirmed.

### Discussion

Study results revealed that, except for hypothesis 1, all other hypotheses were supported. Save for the positive relationship found between ethnocentrism and adoption of an EBA choice strategy (a negative association was posited), significant relationships between cultural factors and adoption of lexicographic



and weighted-additive strategies were revealed. Specifically, Chinese and South Korean customers were more likely to adopt a lexicographic choice strategy when purchasing a mobile phone when they had greater emotional intensity, purchasing experience, and propensity to imitate others. Also, Chinese and South Korean customers were more likely to opt for a weighted-additive choice strategy when they were more patient in making their purchase decisions.

This research also shows that contrary to hypothesis 1, people with higher ethnocentrism are more likely to adopt an EBA choice strategy (they were posited as being less likely to do so). Conceivably, people with higher ethnocentrism may be more likely to use country of origin as one of the aspects in an EBA choice strategy. Thus, those who are more likely to eliminate product options by using country of origin might also have an increased proclivity to adopt other criteria to narrow their choices.

### Theoretical Implications

The present research adds to retailing literature by providing enhanced understanding of factors that influence Chinese and South Korean customers' purchase decision process in a mobile phone market. Specifically, how various cultural and individual factors—ethnocentrism, emotion, purchasing experience, imitation, and patience—affect customers' adoption of lexicographic, EBA, and weighted-additive strategies to purchase mobile phones were explored. Previously, there was a relative paucity of research on how these factors influence Chinese and South Korean customers' *choice strategies*. So, this study partially fills this lacuna. This investigation also provides researchers with a basis for understanding cultural and individual factors that could influence South Korean and Chinese customers' purchase of other electronic products.

This research also offers theoretical contributions to the choice strategies literature

by identifying the impact of cultural and individual factors on customer choice strategies in a mobile phone purchasing context. Although prior research has identified that such factors affect customer choice strategies (Zhang, 2004), no published research was found that specifically investigated their impact on customer choice strategies in a mobile phone purchasing context. As such, by examining the effect of cultural and individual factors on three popularly used choice strategies—lexicographic, EBA, and weighted-additive—in East Asia, the current work undertook exploration of a research issue meriting attention.

### Managerial Implications

Managerially, understanding customers' choice strategies is critical for multi-national companies expanding into China and South Korea. Such knowledge can assist these companies in developing and implementing strategies to meet customers' needs. For instance, acknowledging that customers with certain characteristics (e.g., high in imitation) are more likely to adopt certain choice strategies (e.g., lexicographic) when purchasing cell phones, MNCs can design specific products with attributes that are more likely to be selected by using these choice strategies. In this way, this research should help MNCs create products that might well have an enhanced likelihood of being selected in Chinese and South Korean markets.

### Limitations and Future Research

Despite its theoretical and managerial implications, this research has limitations that should potentially provide opportunities for future research. One major limitation is that solely lexicographic, EBA, and weighted-additive choice strategies were reconnoitered. Other strategies that customers often adopt, such as conjunctive strategy (Bettman, 1979), should be considered in future work. Since conjunctive strategy imposes a cut-off value for every attribute and then comparing each product

against the set of imposed cut-off values (Jedidi & Kohli, 2005; Yee et al., 2007), investigating whether this strategy is adopted more often than other non-compensatory strategies by customers would be interesting. Moreover, subsequent empirical efforts might examine factors that affect Chinese and South Korean customers' adoption of these alternative other strategies.

A second limitation is that data were collected only in China and South Korea. Therefore, findings may not be readily generalizable to other East Asian countries, such as Japan and Mongolia. Research has shown that other East

Asian cultures (e.g., Japan), are different in their cultural values from cultures studied in this research (e.g., Singh et al., 2005). Thus, future research might examine customers' adoption of choice strategies across all East Asian countries.

A third limitation of this research is that although each East Asian country is somewhat different in its cultural values, our results may not account for such differences. As such, factors that are important in Chinese and South Korean cultures may not be as important as factors that affect customers' adoption of choice strategies in other East Asian nations. Future research could examine the foregoing issue.

## References

- Ahmad, S. N., & Richard, M. O. (2014). Understanding Customer's Brand Categorization across Three Countries: Application of Fuzzy Rule-Based Classification. *Journal of Business Research*, *67*(3), 278-287.
- Ajzen, I., & Fishbein, M. (1980). *Understanding Attitudes and Predicting Social Behaviour*. Englewood Cliffs, NJ: Prentice-Hall.
- Alba, J. W., & Marmorstein, H. (1987). The Effects of Frequency Knowledge on Customer Decision-Making. *Journal of Customer Research*, *14*(1), 14-25.
- Araña, J. E., & León, C. J. (2009). Understanding the Use of Non-Compensatory Decision Rules in Discrete Choice Experiments: The Role of Emotions. *Ecological Economics*, *68*, 2316-2326.
- Armstrong, G., & Kotler, P. (2006). *Marketing: An Introduction*. Upper Saddle River, NJ: Pearson-Prentice Hall.
- Bakewell, C., & Mitchell, V.-W. (2003). Generation Y Female Customer Decision-Making Styles. *International Journal of Retail & Distribution Management*, *31*(2), 95-106.
- Balabanis, G., & Diamantopoulos, A. (2004). Domestic Country Bias, Country-of-Origin Effects, and Customer Ethnocentrism: A Multidimensional Unfolding Approach. *Journal of the Academy of Marketing Science*, *32*(1), 80-95.
- Balabanis, G., & Diamantopoulos, A. (2008). Brand Origin Identification by Customers: A Classification Perspective. *Journal of International Marketing*, *16*(1), 39-71.
- Bee, C. C., & Madrigal, R. (2013). Customer Uncertainty: The Influence of Anticipatory Emotions on Ambivalence, Attitudes, and Intentions. *Journal of Customer Behaviour*, *12*(5), 370-381.
- Belz, M., Pyritz, L. W., & Boos, M. (2013). Spontaneous Flocking in Human Groups. *Behavioural Processes*, *92*, 6-14.
- Bernhardt, D., Campello, M., & Kutsoati, E. (2006). Who Herds? *Journal of Financial Economics*, *80*(3), 657-675.
- Bettman, J. R. (1979). *Description and Examples of a Protocol Coding Scheme for Elements of Choice Processes*. Paper presented at the Center for Marketing Studies, University of California, Los Angeles.
- Bettman, J. R., Luce, M. F., & Payne, J. W. (1998). Constructive Customer Choice Processes. *Journal of Customer Research*, *25*(3), 187-217.

- Bhattacharya, A. K., & Michael, D. C. (2008). How Local Companies Keep Multinationals at Bay. *Harvard Business Review*, 86(3), 84.
- Bikhchandani, S., & Sharma, S. (2001). Herd Behavior in Financial Markets. *IMF Staff Papers*, 47(3), 279-310.
- Cannon, J. P., Doney, P. M., Mullen, M. R., and Petersen, K. J.. (2010). Building Long-Term Orientation in Buyer–Supplier Relationships: The Moderating Role of Culture. *Journal of Operations Management* 28 (6): 506-521.
- Carpenter, J., & Fairhurst, A. (2005). Customer Shopping Value, Satisfaction, and Loyalty for Retail Apparel Brands. *Journal of Fashion Marketing and Management*, 9(3), 256-274.
- Carpenter, J. M., Moore, M., Alexander, N., & Doherty, A. M. (2013). Customer Demographics, Ethnocentrism, Cultural Values, and Acculturation to the Global Customer Culture: A Retail Perspective. *Journal of Marketing Management*, 29, 271-291.
- Cha, E.-S., Kim, K. H., & Erlen, J. A. (2007). Translation of Scales in Cross-Cultural Research: Issues and Techniques. *Journal of Advanced Nursing*, 58(4), 386-395.
- Chapman, G. B., Li, M., Vietri, J., Ibuka, Y., Thomas, D., Yoon, H., & Galvani, A. P. (2012). Using Game Theory to Examine Incentives in Influenza Vaccination Behavior. *Psychological Science*, 23(9), 1008-1015.
- Chen, Y. F. (2008). Herd Behavior in Purchasing Books Online. *Computers in Human Behavior*, 24(5), 1977-1992.
- Chen, Y. F. (2011). Auction Fever: Exploring Informational Social Influences on Bidder Choices. *Cyberpsychology Behavior and Social Networking*, 14(7-8), 411-416.
- CIA. (2015). The World Factbook. Retrieved 03, 2016, from <https://www.cia.gov/library/publications/resources/the-world-factbook/rankorder/2003rank.html>
- Costa, C. A. B., & Vincke, P. (1995). Measuring Credibility of Compensatory Preference Statements When Trade-Offs Are Interval Determined. *Theory and Decision*, 39(2), 127-155.
- Counterpoint Research (2015). China: Xiaomi Led the Slow Growing Smartphone Market in 2015. Retrieved 02, 2016, from <http://www.counterpointresearch.com/4q15china>
- Curtis, M. E., & Bharucha, J. J. (2009). Memory and Musical Expectation for Tones in Cultural Context. *Music Perception: An Interdisciplinary Journal*, 26 (4): 365-375.
- Erdem, T., & Keane, M. P. (1996). Decision-Making under Uncertainty: Capturing Dynamic Brand Choice Processes in Turbulent Customer Goods Markets. *Marketing Science*, 15(1), 1-20.
- Fader, P. S., & McAlister, L. (1990). An Elimination by Aspects Model of Customer Response to Promotion Calibrated On UPC Scanner Data. *Journal of Marketing Research*, 27(3), 322-332.
- Fan, J. X., & Xiao, J. J. (1998). Customer Decision-Making Styles of Young-Adult Chinese. *Journal of Customer Affairs*, 32(2), 275-294.
- Fishbein, M. (1963). An Investigation of the Relationship between Beliefs about an Object and the Attitude toward that Object. *Human Relations*, 16 (August), 233-240.
- Fishbein, M., & Ajzen. (1975). *Belief, Attitude, Intention, and Behavior: An Introduction to Theory and Research*. Reading, MA: Addison-Wesley.
- Fox, S. (2011). *The Social Life of Health Information, 2011: Pew Internet & American Life Project* Washington, DC.
- Frank, R. (2001). Asia's Investment Spotlight Sweeps North. *The Wall Street Journal*, 28, 16-17.
- Freimer, M., & Horsky, D. (2008). Try It, You Will Like It-Does Customer Learning Lead to

- Competitive Price Promotions? *Marketing Science*, 27(5), 796-810.
- Gilbride, T. J., & Allenby, G. M. (2006). Estimating Heterogeneous Eba and Economic Screening Rule Choice Models. *Marketing Science*, 25(5), 494-509.
- Greenleaf, E. A., & Lehmann, D. R. (1995). Reasons for Substantial Delay in Customer Decision-Making. *Journal of Customer Research*, 22(2), 186-199.
- Han, S.-H. (2012). South Korea Seeks to Balance Relations with China and the United States. Retrieved 02, 2016, from <http://www.cfr.org/south-korea/south-korea-seeks-balance-relations-china-united-states/p29447>
- Hoyer, W. D. (1984). An Examination of Customer Decision Making for a Common Repeat Purchase Product. *Journal of Customer Research*, 11(3), 822-829.
- Jedidi, K., & Kohli, R. (2005). Probabilistic Subset-Conjunctive Models for Heterogeneous Customers. *Journal of Marketing Research*, 42(4), 483-494.
- Kasper, H., Bloemer, J., & Driessen, P. H. (2010). Coping with Confusion: The Case of the Dutch Mobile Phone Market. *Managing Service Quality: An International Journal*, 20(2), 140-160.
- Kastanakis, M. N. & Voyer, B. G. (2014). The Effect of Culture on Perception and Cognition: A Conceptual Framework. *Journal of Business Research*, 67(4): 425-433.
- Katsikopoulos, K. V. (2011). Psychological Heuristics for Making Inferences: Definition, Performance, and the Emerging Theory and Practice. *Decision Analysis*, 8(1), 10-29.
- Kemp, E., & Kopp, S. W. (2011). Emotion Regulation Consumption: When Feeling Better Is the Aim. *Journal of Customer Behaviour*, 10(1), 1-7.
- Kim, H., & Markus, H. R. (1999). Deviance or Uniqueness, Harmony or Conformity? A Cultural Analysis. *Journal of Personality and Social Psychology*, 77(4): 785-800.
- Kim, T.-Y., Edwards, J., Shapiro, D. (2015). Social Comparison and Distributive Justice: East Asia Differences. *Journal of Business Ethics*, 132(2), 401-414.
- Kim, T.-Y., Wang, C., Mari, K., & Kim, T.-H. (2007). Conflict Management Styles: The Differences among the Chinese, Japanese and Koreans. *International Journal of Conflict Management*, 18(1), 23-41.
- Kim, J.-O., Forsythe, S., Gu, Q., & Jae Moon, S. (2002). Cross-Cultural Customer Values, Needs and Purchase Behavior. *Journal of Customer Marketing*, 19(6), 481-502.
- Kohli, R., & Jedidi, K. (2007). Representation and Inference of Lexicographic Preference Models and Their Variants. *Marketing Science*, 26(3), 380-399.
- Lavie, N. (2005). Distracted and Confused?: Selective Attention under Load. *Trends in Cognitive Sciences*, 9(2), 75-82.
- Lepp, A., Barkley, J. E., Sanders, G. J., Rebold, M., & Gates, P. (2013). The Relationship between Cell Phone Use, Physical and Sedentary Activity, and Cardiorespiratory Fitness in a Sample of US College Students. *International Journal of Behavioral Nutrition and Physical Activity*, 10(1), 79.
- Lerner, J. S., & Keltner, D. (2000). Beyond Valence: Toward a Model of Emotion-Specific influences on Judgment and Choice. *Cognition & Emotion*, 14(4), 473-493.
- Loudon, D. L., & al., E. (1993). *Customer Behavior Concepts and Applications* (4 ed.): McGraw Hill.
- Luchs, M. G., Brower, J., & Chitturi, R. (2012). Product Choice and the Importance of Aesthetic Design Given the Emotion-Laden Trade-Off between Sustainability and Functional Performance. *Journal of Product Innovation Management*, 29(6), 903-916.

- Lynch, J., G., J., & Srull, T. K. (1982). Memory and Attentional Factors in Customer Choice: Concepts and Research Methods. *The Journal of Customer Research*, 9(1), 18-37.
- Manrai, A. K., & Sinha, P. (1989). Elimination-By-Cutoffs. *Marketing Science*, 8(2), 133-152.
- Meyer, J. W., & Rowan, B. (1991). *Institutionalized Organizations: Formal Structure as Myth and Ceremony*. Chicago: University of Chicago Press.
- Pachur, T., & Forrer, E. A. (2013). Selection of Decision Strategies after Conscious and Unconscious Thought. *Journal of Behavioral Decision Making*, 26(5), 477-488.
- Pollay, R. W., Tse, D. K., & Wang, Z.-Y. (1990). Advertising, Propaganda, and Value Change in Economic Development: The New Cultural Revolution in China and Attitudes toward Advertising. *Journal of Business Research*, 20(2): 83-95.
- Richarme, M. (2005). Customer Decision-Making Models, Strategies, and Theories, Oh My! Retrieved 05, 2014, from <http://www.decisionanalyst.com/Downloads/CustomerDecisionMaking.pdf>
- Sharma, S., Shimp, T., & Shin, J. (1995). Customer Ethnocentrism: A Test of Antecedents and Moderators. *Journal of the Academy of Marketing Science*, 23, 26-37.
- Shimp, T. A., & Sharma, S. (1987). Customer Ethnocentrism – Construction and Validation of the Cetscale. *Journal of Marketing Research*, 24(3), 280-289.
- Simon, H. (1955). A Behavioral Model of Rational Choice. *Quarterly Journal of Economics*, 69(February), 99-118.
- Singh, N., Zhao, H., Hu, X. (2005). Analyzing the cultural content of web sites: A cross-national comparison of China, India, Japan, and US. *International Marketing Review*, 22(2), 129-146.
- Stallen, M., De Dreu, C. K. W., Shalvi, S., Smidts, A., & Sanfey, A. G. (2012). The Herding Hormone: Oxytocin Stimulates In-Group Conformity. *Psychological Science*, 23(11), 1288-1292.
- Su, B. (2007). Customer E-Tailer Choice Strategies at On-Line Shopping Comparison Sites. *International Journal of Electronic Commerce*, 11(3), 135-159.
- Sumner, W. G. (1906). *Folkways*. Blaisdell, New York.
- Sun, H. (2009). Understanding Herd Behavior in Technology Adoption and Continued Use: A Longitudinal Perspective. *DIGIT 2009 Proceedings*, 11.
- Sun, H. S. (2013). A Longitudinal Study of Herd Behavior in the Adoption and Continued Use of Technology. *MIS Quarterly*, 37(4), 1013.
- Supphellen, M., & Rittenburg, T. L. (2001). Customer Ethnocentrism when Foreign Products are better. *Psychology & Marketing*, 18(9), 907-927.
- Swait, J., & Adamowicz, W. (2001). Choice Environment, Market Complexity, and Customer Behavior: A Theoretical and Empirical Approach for Incorporating Decision Complexity into Models of Customer Choice. *Organizational Behavior and Human Decision Processes*, 86(2), 141-167.
- TechinAsia (2015). China Has Almost 1.3 Billion Mobile Users, and Half of Them Are on 3G or 4G. Retrieved 01, 2016, <https://www.techinasia.com/china-13-billion-mobile-users-3g-4g>
- Terpstra, V., Foley, J., & Sarathy, R. (2012). *International Marketing*: Naper Press.
- Tsai, W. S., Yoo, J. J., & Lee, W.-N. (2013). For Love of Country? Customer Ethnocentrism in China, South Korea, and the United States. *Journal of Global Marketing*, 26(2), 98-114.
- Tversky, A. (1972). Elimination by Aspect: A Theory of Choice. *Psychological Review*, 79(July), 281-299.



- van der Merwe, D., Kempen, E. L., Breedts, S., & de Beer, H. (2010). Food choice: Student Customers' Decision-Making Process regarding Food Products with Limited Label Information. *International Journal of Customer Studies, 34*(1), 11-18.
- Velásquez, J. D. (1998). *When Robots Weep: Emotional Memories and Decision-Making*. Paper presented at the AAAI/IAAI.
- Watson, J., & Wright, K. (2000). Customer Ethnocentrism and Attitudes toward Domestic and Foreign Products. *European Journal of Marketing, 34*(9&10), 1149-1166.
- Whang, H., Yong, S., & Ko, E. (2016). Pop culture, destination images, and visit intentions: Theory and research on travel motivations of Chinese and Russian tourists. *Journal of Business Research, 69*(2), 631-641.
- Winterich, K. P., & Haws, K. L. (2011). Helpful Hopefulness: The Effect of Future Positive Emotions on Consumption. *Journal of Customer Research, 38*(3), 505-524.
- Yee, M., Dahan, E., Hauser, J. R., & Orlin, J. (2007). Greedoid-Based Noncompensatory Inference. *Marketing Science, 26*(4), 532-549.
- Yoo, B., & Donthu, N. (2005). The Effect of Personal Cultural Orientation on Customer Ethnocentrism: Evaluations and Behaviors of U.S. Customers toward Japanese Products. *Journal of International Customer Marketing, 18*(1/2), 7-44.
- Zaltman, G. (2003). *How Customers Think: Essential Insights into the Mind of the Market*. Boston, MA: Harvard Business School Press.
- Zane, S. (1992). Research on Drug Abuse among Asian Pacific Americans. *Drugs and Society, 6*(34), 181-209.
- Zhang, H. (2004). What are Chinese Short of Compared with Koreans? *China Culture and History Press*.



# CUSTOMERS' OPINION AND RECEPTION OF INNOVATION IN RETAIL MARKET IN CROATIA

Ivan Kovač, Marko Babić and Robert Bajkovec

## **Abstract:**

*Driven by innovation and concentration processes, large retailers in Croatia apply many innovations in order to improve and maintain their competitive advantage. Application of innovation in retailing is oriented towards satisfaction of consumers' needs and towards improving consumers' loyalty. This paper gives insights into the concept and appearance of innovations in Croatian retailing market together with the perception of consumers towards applied innovation in retailing market. The focus of the paper is put to the innovations in Croatian retailing market. Then the primary research results are discussed based on analysis of survey results on retail customers using innovation in their everyday life.*

**Keywords:** retailing, innovations, globalization, Croatia, retail industry, consumers

## **INTRODUCTION**

Retailing is a business that enables the firm high level of interaction with the customers it serves. Many authors in the field of retailing suggest that retailers need to innovate in order to be able to meet the growing demands of their customers and to be successful on their current market. Moreover, customers' attitudes and behaviors both influence and are influenced by actions of competing retailers, which means that retailing innovation depends on its degree of suitability to consumers.

Over the three decades, modern retailing has become increasingly global and the retail market environment in numerous countries worldwide was influenced by global forces. Furthermore,

the influence of these globalization forces is evident in various aspects of retailing, for example in the retailing supply chain, processes, formats, product assortment, customer experience, information technology, new media, handling of payment, order fulfillment and finally branding (Verhoet, Reinartz and Krafft, 2010). Moreover, in globalized economy, retail becomes increasingly important economic sector and among the most progressing ones since this industry continues to grow despite the global economic crisis (Balasescu, 2013).

In order to improve or to maintain their competitive advantage, retailers apply many innovations which tend to improve overall shopping experience of their consumers. For instance: scanning systems, self checkout systems, customer loyalty program based on intensive use of modern marketing intelligence systems, customer experience management systems, various web and mobile commerce applications etc (Burke, 2010.). Mobile

**Ivan Kovač**, Ph.D. is Assistant Professor at Faculty of Economics and Business, University of Zagreb, Trg J. F. Kennedyja 6, 10 000 Zagreb, Croatia, email: ivankovac@efzg.hr

**Marko Babić**, LL.M., email: mbabic@hgk.hr

**Robert Bajkovec**, univ.bacc.oec., rbajkovec@yahoo.com

technology should be considered as one of the most attractive ones in the process of developing innovations. Consequently, process of buying is being enhanced by retailers who introduce, for instance, smartphones and mobile applications as shopping tools (Knežević et al., 2015.). Speaking in general, radical innovation culture has substantial influence on trade development. In relation to that, retailers should take into account innovation culture development indicators before making decisions on suppliers. Radical product innovation and more precisely better customer relations can surely be guaranteed by strong innovation culture (Baković et al., 2014.).

All this enables implementation of new ways of selling products, ordering, paying, searching information and leaving comments on special web pages where other potential customers can read it and make a decision of buying products and services.

Customers use innovations for various motives and reasons, but mostly because of raising the efficiency of their purchase and life. Although consumers are increasingly sophisticated in their technological interactions, they may avoid certain innovations if uncomfortable, even when benefits are obvious (Meuter et al., 2005).

Therefore, the goal of this paper is to explain how customers perceive applied innovations in retailing industry in Croatia.

Firstly, we are going to discuss maturity of Croatian retailing market, then we will give an overview on retailing innovation and finally, we will discuss the results of survey on attitudes of retail customers in Croatia.

## **DISCUSSION ON MATURITY OF CROATIAN RETAILING MARKET**

To begin with, customer based challenges refer to differences in the characteristics of customers in different types of markets and the ability of retailers to address the current and latent needs of customers, better than offerings that already exist. Therefore, many retailers have noticed the importance of involving customers in developing innovations. In other words, many companies have recognized that getting customers engaged in innovation processes is a crucial step (Verhoet, Reinartz and Krafft, 2010). Secondly, industry based challenges refer to innovation challenges and opportunities related to differences in the nature of competition, technology and suppliers in mature, emerging and less developed markets (W.Reinartz et al., 2011). The industry context, particularly the intensity of competition in a market and supply chain management, has been identified as a major driver of success versus failure in innovation management (Ganesan et al., 2009). Last but not least challenges and opportunities are legal and regulatory based, and they refer to differences in governance and regulations in the different markets. They include stability and volatility of political and legal system and research and development performance. To sum up, these three environmental forces drive retailers' efforts to provide better services and products to their customers in different types of markets through innovations.

In order to understand the appearance and concept of innovations in different types of markets and above all in Croatia, there have been explored and described some basic characteristics on mature, emerging and less developed markets that represent fields where retailing innovations can grow and develop.

**Table 1:** Special characteristics of Croatian retailing market compared to global retailing markets

Different types of markets	MATURE MARKETS	EMERGING MARKETS	LESS DEVELOPED MARKETS	CROATIA
P L A C E S	Western Europe, North America, parts of Asia	Asia, Central and South America, Eastern Europe, BRIC countries	Africa, some parts of Asia and south America	Croatia
C H A R A C T E R I S T I C S	Basic needs of consumers are met (Lusch et al, 2007). High purchasing power of consumers.	Absence of well-developed and functioning retailing distribution network, mass media, transportation and storage infrastructure. Rapid economic growth, industrialization, urbanization, informationalization	Specific local conditions. Many customers do not have bank accounts. Low income levels. Lack of sophisticated legal or financial system. On the base of the pyramid markets.	Unemployment, low salaries. High rate of debt on balance of paying, dominant import. Most of exports through services especially during the tourism season (invisible export). „Brain drain“. Internationalization. Concentration. Lack of investments.
<u>Retailing innovation challenges</u>	Replace goods, services and experiences that are currently being consumed with innovative' ones as a path of growth. Fulfill the higher-order needs of consumers. Create superior value through innovations that go beyond satisfying basic needs. Customization, co-creation, interaction, individualization, entertaining experience, unique products.	Increase number of distributors in rural areas by helping people to start their own small stores. Micro-entrepreneurs. Offer products in small package size to fit on crowded shelves.	Mobile phone based money transfer system can be solution for paying problems. Design product and supply chain management strategies.	Consumers in Croatia are well informed about and exposed to goods and services from mature markets, while still conforming to certain traditional habits, attitudes and structures. Electronic commerce. CRM. Professional and well educated employees. Energy-saving technology.
G O A L S	Build competitive differentiation advantage. Transform available data into decision-relevant information. Developing new data analysis.	Emerging market is the largest market – attract many consumers by providing products and services with global characteristics that are adapted to specific local places.	Consolidation of existing large number of very small, locationally separated retailers.	Mix of three market goals. Information, globalization, consolidation.

Source: adapted according to W. Reinartz et al., 2011.

Table 1 provides information about characteristics in different markets, challenges and goals that retailers are supposed to win in order to survive in turbulent and dynamic market environment. It is quite obvious that there are huge differences in conditions especially between mature and less developed markets, which are the results of differences in level of income, life standards, infrastructure, political and economic stability, history, technology, habits and behavior of local people and many other factors. Historically, according

to Immelt, Govindarajan and Timble, (2009), retail firms have innovated in their home country and then rolled out these innovations in other countries. In broader context of innovation literature, this has spurred debate and discussions on trickle-down versus trickle-up innovation (trickle-up or reverse innovations refer to successful innovations developed in emerging markets by multinational enterprises being subsequently launched in mature markets in which they compete). Everything seems to suggest that Croatian retailing market together

with similar types of markets were influenced for many years by the appropriate innovations that were already existed in mature developed markets. Therefore, the most basic needs of consumer are being more than adequately met and retailers in Croatia are oriented towards fulfillment of the higher-level of consumers' needs. That means that the retailers have to invent ways how to sell products to customers and bring added value to them.

On the other hand, the evidence that Croatian market is still not in the mature stage is its unemployment combined with a growth in retail prices and costs of living. All that combined produces low purchasing power that affects Croatian consumers, who are highly price sensitive. This situation leads to the further expansion of mass retailers due to their low prices and tendency to innovate in order to reduce costs.

In last ten years, the competition on the domestic retail market has been heated up with foreign retailers entering the market and changing the rules of survival on market with innovations and meeting the needs of customers. The process is called internationalization and had a great impact on the overall Croatian retailing market. Moreover, in the structural meaning, the market is in the process of intensive retail concentration, as well as a further increase in the share of expansive retail facilities which leads to increased dynamics of innovation (Balasescu, 2013.).

Structural changes in certain market have been influenced by the process of concentration. Good example could be found within retail market structure where large sales area has replaced small shops. Croatian market has followed example of the rest of Europe where hypermarket has grown much faster as a retail format in comparison with other retail formats (Knežević et al., 2014.).

## **A THEORETICAL INSIGHT INTO CONSUMERS' PERCEPTION ON RETAIL INNOVATION**

There are two main reasons why retailers are introducing innovations in their business: (1) to improve the experience of costumers or usefulness of purchasing and (2) to reduce costs of operation. Retailers are improving the customer experience by taking all kind of actions which enhance customer perception of the value of product or service. These are the actions related to the interaction of buyers with sellers, but also images of the entire company. Nowadays it's the most important to be present on social media to help consumers to be better informed about any changes going on with their retailer. That way the retailers can easily and quickly find out the needs and desires of its customers and fulfill them in the way they expect. By using the latest communication technology and various applications created to make a special connection with consumers, retailers have an easier access to their target customers. The increase of the number of targeted customer's results with the increase in the sales of retailer's assortment which leads to higher profits, as the most important objective of the implementation of innovation in retailing business.

Customer perception towards innovation in retailing market is influenced by their technological readiness. (Parasuraman, A., 2000) The willingness of the consumer to accept technological novelties which will help to achieve goals in their life is called the technological readiness of consumers. When consumers use the new technology they are not passive recipients of innovations. They look for new innovations, they want to experiment with them, evaluate them, to develop feelings about them, and gain experience through the application and dialogue with other consumers. Factors that influence the rate of diffusion of innovation are customer experience and

perceived value of innovations. Innovations characteristics have a major impact on the rate of adoption of innovations among consumers. Parasuraman (2000) attempted to define what affects the customer to use a self-service technology and found certain characteristics that influence the adoption of new technologies. He defined the technological readiness as a tendency for people to adopt and use new technologies. This leads to the conclusion that the higher technological readiness of people allows retailers to easier implement innovation in their business systems, giving consumers greater satisfaction when using these new technologies. In the study (Kaushik, A.K., Rahman, Z., 2015) of self-service retail technology adoption they conclude that retail firms need to formulate effective strategies to reduce consumer's resistance to adopt them. Nonetheless, consumer resistance to change is not limited only to the pre-adoption stage. They might become resistant to a new innovation even after initial adoption. Resistance might manifest during the consumption stage which follows the adoption stage. Customers might neglect the innovation when they limit their use to specific occasions. Moreover, they can abandon innovation or make a distance from it by avoiding its usage. To counter these practices, retailers have to establish a connection through a user-friendly interface between customers and innovation, encouraging customers to thoroughly learn the operations, strengths and weaknesses of the new innovations.

The consumers' perception of the value of an innovation is influenced by the user's perception of how unique the innovation is positioned in relation to close substitutes. Meaning, that if there is an innovation of an improved model of mobile phone having some additional features, such an innovation would not be perceived by the user as generating greater additional value, as the value of the phone's basic functionality have already been met. Therefore, such an

innovation would be considered to have a weak position in the consumers' mindset. Advertising helps to strengthen the perception of the product while trials give the first-hand opportunity to sense and feel the product and thus change its perception (Sikdar, A., Vel, P., 2010).

According to innovation diffusion theory, the interest of customers in the novelties of markets depends on novelty seeking. Novelty seeking refers to customer values related to experimentalism and customer interest in trying new things and facing new stimulating challenges (Rogers, E.M., 1995). Based on this statement we can conclude that there are two types of consumers, those that are innovative and those who are conservative. Innovators are defined as those who adopt an innovation earliest. Those consumers who purchase early and do so purely on their own initiative are the true innovators in any market, and it is they who often determine an innovation's future. Other early buyers, who adopt having benefited from the advice or experience of these innovators, do deliver benefits to the provider, but clearly cannot be expected to enter the market until the independent innovators have. They are responsible for generating word-of-mouth and setting an example for more conservative later buyers. Attracting a large share of their customers is vital to gaining large market share, and a product or service needs to appeal to heavy users such as innovators to be successful in the long run (McDonald, H., et al. 2007). Conversely, when establishing a relationship with conservative customers, companies should better focus on highlighting the traditional features of their brands and products. For example, price or quality: scholars have demonstrated that conservative customers are risk-averse and prefer basing their decisions on traditional, stable, secure and widely accepted economic metrics (Pérez, A., et al. 2015). The safest strategy is to target both innovators and

early adopters, but to make sure that innovators are targeted first and, perhaps, most intensively. This should be done in a manner that encourages them to engage in a dialogue with the organization and other potential consumers (McDonald, H., et al. 2007).

In the (Pereira, R.E., 2002) study of an adopter-centered approach to understanding adoption of innovations, author gave us his model of steps that every innovation adopter has to pass in order to fully understand and use the innovation. His model is called the sensemaking model, and it describes the evolution of the adopter's mental framework. Sensemaking is defined as the cyclical process of taking action, extracting information from stimuli resulting from that action, and incorporating information and stimuli from that action into the mental framework that guide further action. It starts with the knowledge stage where an individual is exposed to an innovation and gains some understanding of how it functions. This exposure may have happened by chance, or may be the result of an effort to seed out the innovation once the individual had identified a need for it. The second stage is the persuasion stage. In that stage a favorable or unfavorable attitude towards the innovation is developed. Formation of this attitude is dependent upon the opinions of peers and their experiences. In the third stage, the individual engages in the activity that leads to a choice to adopt or reject an innovation. The sensemaking model suggests that the individual has been engaging in adoption-related or rejection-related activities all along, and will continue to do so once the

decision is made. In the implementation stage the adopter puts the innovation into use. During the implementation, the adopter will extract and incorporate many more cues from his experience with the innovation. In the last stage or the confirmation stage the individual seeks reinforcement of his adoption or rejection decision. Having performed a decision-related action and possibly implementation to retrospectively assess what he has done and what he should do next, including the possibility of reversing the previous adoption/rejection decision.

## **DISCUSSION OF THE PRIMARY RESEARCH RESULTS**

### ***Sample and Methodology***

The primary survey was conducted on a sample of 304 consumers of different ages, gender and education. Table 1 shows the sample structure. The study included 54.3 percent of female and 45.7 percent of male persons. Most respondents, 60.9 percent completed high school, 32.9 percent of respondents have some degree of a college education while only 6.3 percent of respondents have had primary education. The majority of respondents, or 34.5 percent, were less than 30 years old, customers between 30 and 40 years were interviewed with 17.8 percent of respondents, customers between 40 and 50 years with 18.8 percent of respondents, customers between 50 and 60 years with 17.4 percent of respondents and customers over 60 years with 11.5 percent of respondents.



**Table 1:** Sample characteristics (N=304)

Characteristic	Options	Relative frequencies (%)
gender	male	54.3
	female	47.7
completed level of education	primary education	6.3
	high school	60.9
	college education (or higher)	32.9
age	less than 30 years old	34.5
	between 30 and 40 years	17.8
	between 40 and 50 years	18.8
	between 50 and 60	17.4
	years more than 60 years	11.5

Source: own work

A questionnaire of 17 questions divided into 3 groups was developed and used in this research. The first group of questions examined the demographic situation of the respondents. With the questions about age, education, income and gender, we collected the data that helped us with solving hypothesis. The second group of questions examined the willingness of consumers to use new technology, ranging between strongly agree and strongly disagree. In the third group of questions consumers responded about which innovations they use and what are their reasons for using or not using of innovation. With the answers to these questions, we found out what is the level of awareness of consumers about the use of retail innovation.

Consumers in developed countries are faced with the problem of lack of time, parking spaces or delivery of goods ordered over the Internet on time. In less developed countries, the problem is in the lack of adequate transportation as the reason for losing time. Ultimately innovations are a less expensive and time consuming manner way to meet the requirements of customers (Reinartz, W. et al., 2011). According to a survey (Meuter, M.L., et al. 2005) of reasons for accepting and using SST (self-service technology), the results show that

the main reason for using SST are cash and time savings, compared to traditional cash registers. Adoption of innovation often requires a change in consumer habits and forces them to develop new habits. On the other hand, the consumers create a natural resistance to innovation, which is the normal consumer response. According to a survey (Laukkanen, T. et al. 2007) on the adoption of mobile banking, older customers feel more fear towards an adoption of innovation than younger ones.

Based on the above mentioned literature, in this paper we will focus on 3 hypotheses:

H1: Croatian consumers recognize most of the innovations in retail market.

H2: Consumers use retail innovations in order to save time and money.

H3: Consumers avoid using innovations due to their complexity and the risks of use.

### Discussion of the Results

The first hypothesis we will try to prove through a table and graph on recognizing innovations in the Croatian retail market. Table 2 shows 10 innovations, which can be found on the domestic retail market. Out of these ten innovations respondents could choose all the innovations they know that exist in our market.

**Table 2:** Consumer recognition of innovations in the Croatian retail market

	Number of respondents	Relative frequency %
<i>Private Labels - Trademarks (such as: K-Plus, S-budget)</i>	274	90
<i>Discounts for seniors or students on certain days or certain goods</i>	249	82
<i>Website retailers (on-line catalogs and coupons)</i>	244	80
<i>Ecologically produced goods</i>	212	70
<i>On-line shops</i>	187	62
<i>Biodegradable bags</i>	181	60
<i>Self-service cash registers</i>	179	59
<i>Mobile banking (payment by mobile phone M-zaba, M-PBZ)</i>	157	52
<i>Cards for contactless payment (Inspire card)</i>	154	51
<i>Ordering via Facebook</i>	148	49
<i>Not recognizing any innovation</i>	2	1

Source: own work

According to the distribution of subjects more than half of consumers recognize all these retail innovation except ordering via Facebook where as many as 156 (51%) of respondents did not recognize the innovation. Out of all the offered innovations, most respondents said they recognize the innovation of private label (trademark) with more than 90%. After trademarks, with almost 82 percent are following discounts for seniors and students for specific goods or days. The third most recognized innovations, with 80.3 percent, are retailer's websites. On the opposite side of the table are innovations that are at least recognized: retailing via Facebook page, followed by contactless cards with 50.7 percent, SST-s with 58.9 percent, biodegradable bags with 59.5 and online shops with 61.5 percent. These results are consistent with previous research (Hristov, L., et al., 2015) of the reasons for managers to innovate, where they state that the radical transformation in the form of high-tech innovations occur much less frequently in

relation to continuous and incremental growth of technologically simple innovations. The reason is that retailers prefer to adapt to the circumstances and characteristics of the market, as well as the needs of customers with simpler and easier technological solutions.

Out of 304 respondents, only 1 percent, or 2 respondents stated that out of ten mentioned innovations they don't recognize any innovation. It carries a conclusion that retailers in Croatia are doing a good job in promoting its competitive advantages, and that almost any investment in innovation or product supply is certainly worth it. Such results confirm the hypothesis (H1).

It is in the nature of human to be sociable, which means that they try to spend more time with their family and friends, and the way to save the lost time is through the use of innovation in retail. Table 3 presents reasons for consumer's use of innovations.

**Table 3:** Reasons for using the innovative retail technologies in Croatian retail

<i>The reason for the use of innovative technology in retail</i>	<i>Number of respondents</i>	<i>Relative frequency%</i>
<i>The process of shopping is easier and quicker</i>	199	65
<i>It makes me more efficient in buying and life</i>	119	39
<i>Their use reduces the cost of purchase</i>	99	33
<i>Using the latest technology is fun.</i>	40	13
<i>I like to use new technology.</i>	32	11
<i>No answer</i>	27	9

Source: own work

Results in the Table 3 show that 65 percent of respondents believe retail innovation are saving time while 39 percent believe that innovation makes them more effective in shopping and life. Results show that the first and main reason for the use of new technologies is saving valuable time. As the third most important reason for using innovation, with 33 percent, is that their use reduces costs for the purchase, which is a direct indicator of the importance of price for Croatian consumer. From all this we can conclude that the hypothesis (H3) is valid.

The third hypothesis (H3) claims that consumers avoid the use of innovation due to their complexity and the risks of use. In the past, new technology in retail was predominantly functioning in an automation capacity such as speeding up routine tasks and communications. The technologies used by today's retailers, such

as electronic data interchange (EDI), POS cash register, inventory management systems, customer relationship management, data mining, Internet sales, RFID technology and the like, have changed the role of customers and put on them more responsibilities and obligations. While automation is still important for buyers, information functions are used to strategize new ways to use information to increase profits and customer service and have become a necessity in doing business for buyers (Fiorito, S.S., et al. 2010). Today's customers have to be technologically informed in order to use all the innovations that their retailers use. To prove our hypotheses that fear as a result of the use of risk is an important factor in the acceptance of innovative retail technologies, we cross tabulated results out two questions by which we have established the state of consumers mind in the Croatian retail market (see Table 3).

**Table 3:** Cross tabulation frequencies

		I still prefer the traditional way of shopping in stores			Total
		I strongly agree	I partially agree	I strongly disagree	
I felt the fear of using new technology	I strongly agree	66	20	2	88
	I partially agree	47	55	19	121
	I strongly disagree	20	39	36	95
Total		133	114	57	304

Source: own work

**Table 4:** Chi-Square test of perceived risk as an obstacle for the acceptance of new technology

Chi-Square Tests			
	Value	df	Asymp. Sig. (2-sided)
Pearson Chi-Square	70,890 <sup>a</sup>	4	,000
Likelihood Ratio	74,376	4	,000
Linear-by-Linear Association	64,767	1	,000
N of Valid Cases	304		

a. 0 cells (0, 0%) have expected count less than 5. The minimum expected count is 16,50.

Source: own work

In advance, we applied Chi-Square test to prove that fear of technology influences the preference on innovation usage (see Table 4). Given that the probability of the chi-square test was  $p=00$  the second hypothesis may be accepted, saying perceived risk of using the retail innovation is an important predisposition for the acceptance of new technologies.

There are two reasons why consumers feel unease, and those are: security and privacy. Security refers to the fear of financial loss and privacy is related to the ethical treatment of the customer's personal information (Laukkanen, T., et al., 2007). Consumers in Croatia are obviously aware of the risks of doing business with the use of the Internet and the new technology, but it seems that they do not know how to protect themselves against such risks. This situation in the minds of Croatian consumers confirms (H3).

## CONCLUSION

In the last decades retail business is characterized by internationalization and

concentration which intensified competition in retail market. New technology provides a wide spread of opportunities for retailers to explore new modern and better organized retailing trading in order to gain more customers. Croatian retailing market together with similar types of markets were influenced for many years by the innovations that already existed in mature developed markets.

In primary research we have proved that consumers in Croatia recognize innovation in the retail market. In addition, presented results show that the main reason for the use of new technologies is saving valuable consumers' time while lower cost of the purchase is the third most important reason for using retail innovation. And, finally, the research confirmed that the fear of risk and complexity of using new technologies is a significant obstacle to consumers' innovation usage. Therefore, in the future, retailers should focus on education of consumers in order to decrease their fear of technology.

## REFERENCES

- Baković, T., Lazibat, T., Sutić, I. (2013), "Radical Innovation Culture in Croatian Manufacturing Industry". *Journal of Enterprising Communities: People and Places in Global Economy*, 7(1): pp. 74-80
- Balasescu, M., (2013) "The Influence of Innovations and Technology on the Future of Retail", *Bulletin of the Transilvania University of Braşov* Vol. 6 (55) No. 2 – 201 Series V: Economic Sciences
- Burke, Raymond R. (2010), „The Third Wave of Marketing Intelligence“, in *Retailing in the 21st Century – Current and Future Trends*, Krafft

- Manfred and Mantrala Murali K., eds (2nd ed.). Berlin: Springer, 159-71.
- Fiorito, S.S., Gable, M., Conseur, A., (2010), „Technology: advancing retail buyer performance in the twenty-first century" *International Journal of Retail & Distribution Management*, Vol. 38 Iss 11/12 pp. 879 – 893
- Ganesan, S., Morris, G., Sandy, J., Palmatier, R.W., Weitz, B., (2009), "Supply Chain Management and Retailer Performance: Emerging Trends, Issues and Implications for Research and Practice", *Journal of Retailing*, 85 (1), pp. 84-89
- Hristov, L., Reynolds, J., (2015), "Perceptions and practices of innovation in retailing" *International Journal of Retail & Distribution Management*, Vol. 43 Iss 2 pp. 126 – 147
- Kaushik, A.K., Rahman, Z., (2015), "An alternative model of self-service retail technology adoption", *Journal of Services Marketing*, Vol. 29 Iss 5 pp. 406 – 420
- Knežević, B., Deliđ, M., Kukić, N., (2015), "Smartphones and Mobile Applications as Tools for Grocery Shopping", *Proceedings of the International Scientific Conference Zagreb, Croatia, 18th and 19th November 2015, Trade Perspectives 2015: Innovations in Food Retailing*, Knego, N., Renko, S., Knežević, B., pp. 164-176
- Knežević, B., Knego, N., Deliđ, M., (2014), "The Retail Concentration and Changes of the Grocery Retail Structure", *Journal for International and European Law, Economics and Market Integrations*, Vol. 1 No. 2, pp. 37-51
- Laukkanen, T., Sinkkonen, S., Kivijärvi, M., Laukkanen, P., (2007) "Innovation resistance among mature consumers", *Journal of Consumer Marketing*, Vol. 24 Iss 7 pp. 419 – 427
- McDonald, H., Alpert, F. (2007), "Who are "innovators" and do they matter? A critical review of the evidence supporting the targeting of "innovative" consumers", *Marketing Intelligence & Planning*, Vol. 25 No. 5, pp. 421-435.
- Meuter, M.L., Bitner M.J., Ostrom, A.L., Brown, S.W. (2005), "Choosing among alternative service delivery modes: an investigation of customer trial of self-service technologies", *Journal of Marketing*, Vol. 69, pp. 61-83.
- Parasuraman, A., (2000), "Technology-Readiness Index (TRI): A Multiple-Item Scale to Measure Readiness to Embrace New Technologies" *Journal of Service Research*, Vol.2 (4): 307-320
- Pereira, R.E., (2002), "An adopter-centered approach to understanding adoption of innovations", *European Journal of Innovation Management*, Vol. 5 Iss 1 pp. 40 – 49
- Pérez, A., Rodríguez del Bosque I., (2015), "How customer novelty seeking influences customer CSR perceptions", *Marketing Intelligence & Planning*, Vol. 33 Iss 4 pp. 486 – 507
- Rogers, E.M. (1995), "Diffusion of Innovations: 4th Edition" Free Press, New York, NY.
- Reinartz, W., Dellaert, B., Krafft, M., Kumar, V., Varadarajan, R., (2011), „Retailing Innovations in a Globalizing Retail Market Environment" *Journal of Retailing*, 87 (1), 53-66.
- Sikdar, A., Vel, P., (2010), "Getting the customer interested in your innovation: role of distribution and promotion strategies", *Business Strategy Series*, Vol. 11 Iss 3 pp. 158 – 168
- Verhout, P.C., Reinartz, W., Krafft, M. (2010), "Customer Engagement as a New Perspective in Customer Management", *Journal of Service Research*, 13 (3), pp. 247-252

#### ACKNOWLEDGEMENT

The authors thank Ivan Novak, Ph.D. for his valuable support and insight in statistics methodology issues.

# UNDERSTANDING CONSUMERS' BEHAVIOUR TOWARDS ONLINE SHOPPING: A STUDY OF ONLINE SHOPPERS IN ANAMBRA STATE

I.C Nwaizugbo and Ifeanyichukwu C.D

## **Abstract:**

*This study centers on Consumers' Behaviour towards Online Shopping in Anambra state. Online shopping is still a new and emerging area of business management and information technology. Presently, increasing number of Nigerians are shopping online, but it is not clear what drives them to shop in this way, thus, the major problem of this study. The objective sought to examine the relationship between perceived outcome, shopping orientations, shopping motivations, normative beliefs, and past experience on online shopping. 323 online shoppers in Anambra State were selected conveniently as respondents to elicit the required information using structured questionnaire. Multiple Regression was used to test the hypotheses. Result revealed that normative beliefs, and past experience has significant effect on online shopping while perceived outcome, shopping orientations and shopping motivations was seen to have no significant effect. The researcher recommended that e-stores should offer superior values to shoppers. Also, strategies should be put in place to further increase access to the internet and draw investments into the telecommunications industry to not only fuel the success of e-commerce but also to boost the Nigerian economy.*

**Keywords :** *Online shopping, consumer Behaviour, Perceived Outcome, Shopping Orientation, Shopping Motivation, normative beliefs, past experience.*

## **Introduction**

It has been more than a decade since business-to-consumer electronic commerce (e-commerce) first evolved. Even today, electronic commerce remains a relatively new emerging and constantly changing area of business management and information technology. E-commerce involves all financial and informational electronically mediated exchanges between an organization and its external stakeholders. It also involves sharing business information, maintaining business relationships and conducting business transactions by means

of telecommunication network. Recently, electronic commerce has been redefined by the dynamics of the internet and traditional e-commerce rapidly moving to the internet. E-commerce is said to be an essential characteristics of the internet era and an irreplaceable marketing channel in business transactions (Chen, 2009).

The internet is an open World Wide communication network linking countless number of computer networks throughout the world. Also, it has developed into a vast global market place for the exchange of goods and services. In many developed countries, the internet has been adopted as an important

**I.C Nwaizugbo** is Professor at Nnamdi Azikiwe University Awka, email: ic.nwaizugbo@unizik.edu.ng  
**Ifeanyichukwu C.D**, Nnamdi Azikiwe University Awka, email: cd.ifeanyichukwu@unizik.edu.ng



medium, offering a wide assortment of products with 24 hour availability and wide area coverage. An increasing number of firms and organizations are exploiting and creating business opportunities on the internet. With the advent of the internet, the term e-commerce began to include : electronic trading of physical goods, and intangibles such as information and all the steps involved in trade such as online marketing, ordering, payment and support for delivery, the electronic provision of services such as after sales support and online legal advice (Liang and Lai, 2000). The wide range of business activities related to e-commerce brought about a range of new terms and phrases to describe the internet phenomenon. These include i-commerce (internet commerce), e-retailing, virtual stores, cyber stores, e-shop, e-store etc. Today, the internet has captivated the attention of retail marketers. The internet as a retail outlet is moving from its infancy used by only a few to a market with significant potential.

Nigeria is the fastest growing telecommunication country in Africa (Ayo, Adewoye, and Oni, 2007). The growth of a number of internet users from year 2000 to 2010 is sporadic as it recorded 21.891.1% growth rate! According to the Internet Live Stats (2010), there were 200,000 internet users in Nigeria in year 2000. This number is however less than 1% of the national population (precise 0.1%). In year 2006, the number has grown to 5,000,000 (again just 3.1% of the national population). This figure doubled in 2008 with 10 million people having access to the internet. In 2009, the figure went above double as 23,982,000 million people used the internet in Nigeria. By June 2010; the number of internet users has grown to 43,982,200 that is, 29.5% of the country's population. The increasing users of internet in Nigeria from 0.1% in 2000 to 29.5% of its population in June 2010, revealed that the use of the internet in the country is growing at a sporadic rate and still has the potential to grow higher (Ayo, Adewoye and Oni, 2011).

Online shopping is becoming quite popular in Nigeria, due to its relative convenience and the reasonable prices of goods and services available online. In 2012, expenditures in online stores increased from #50 billion in 2010 to #378 billion (Philips Consulting, 2014). The growth of the online shopping sector is directly linked to internet penetration and the number of internet users has also grown globally and in Nigeria too. Online shopping offers various benefits for the retailer- expanded geographical reach, lower cost and complete range of product. Nevertheless, challenges like low internet penetration rate in Nigeria as when compared to other developing/developed countries, security concerns associated with financial and personal data etc. still abound. Online shopping is basically a process of buying and selling of goods and services on World Wide Web (Forsythe and Shi, 2003). Internet shopping is fast growing in Nigeria and major online shopping mall includes Jumia.com, Konga.com, Taafoo.com, Slothlimited.com, Kaymu etc. This study will also consider free classified advert sites like OLX.com.ng, price comparison sites like price check.com.ng, coupon selling sites like dealdey.com as online stores. Online shopping behaviour (also called online buying behaviour) refers to the process of purchasing products or services via the internet (Liang and Lai, 2000) and Online shopping attitude refers to consumers' psychological state in terms of making purchases on the internet (Li and Zhang, 2002). Consumer behaviour as regards shopping online describes the processes involved when individuals or groups select, purchase, use or dispose products, services, ideas or experience to satisfy needs and wants (Solomon, 2010). This process is similar to the traditional shopping behaviour. This study therefore seeks to know consumers' behaviour towards online shopping in Anambra State.

## Theoretical and Empirical Literature Review

### *Online Shopping*

This is a component of shopping but involves buying and selling on World Wide Web. Online shopping is basically a process of selling and buying of goods and services on World Wide Web. Internet shopping has become the fastest growing as regards use of the internet and most online consumers use information gathered online to make purchases off-line (Dave, Chadwick, Johnston & Mayer, 2006). Online shopping evokes buying products and services from a bricks-and mortar retailer or shopping centre and the process is called business-to-consumer (B2C) online shopping. Geissler and Zinkhan (1998) claimed that the internet shifted the balance of power in favour of consumer as it became very easy for them to make shopping comparison and evaluate alternatives without being pressured by sales people. The internet makes life simple and innovation. People are doing business online and trade has become more easy and fast due to this. Internet provides new ways to promote business. Website becomes the essence of online business as to show their services and products. Internet gathers all competitors and consumers in one place. It brings new lane to promote, advertise products and services in market.

However, despite these advantages, disadvantages still abound. Consumers develop low trust and perceive elevated risk of due to lack of face-to face communication (Xiao and Benbasat, 2007). Online consumers are always seeking new products, new attractiveness and the most important thing being price compatibility with their budget. The internet is the best way to save time and money though purchasing online within their range of budget at home or anywhere.

Consumers' Behaviour Towards Online Shopping

### *Perceived Outcome*

Perceived outcome refers to the perception of possible outcomes (positive or negative) of certain behaviour (Limayem, 2000). It can also be considered as a cognitive behavioural belief similar to the subjective probability that the behaviour will produce a given outcome (Ajzen, 1991). The risks associated with online shopping includes security risks, credit card risks, privacy risks etc. Online shopping brings benefits to consumers in terms of convenience, time saving, searchability and product information. Perceived outcome in online shopping refers to both potential benefits of a shopping and risks associated with online shopping (Zhou, Dai and Zhang, 2007).

H<sub>1</sub>: There is a significant relationship between perceived outcome and online shopping.

### *Shopping Orientation*

Shopping orientation was seen to have a significant impact on online shopping (Donthu and Garcia, 1999; Korgaonkar and Wolin, 1999; Li and Russel, 1999). As a shopping behaviour measure, shopping orientations are intended to capture the motivations of shoppers and the desired experiences and goals they seek when completing their shopping activities (Stone, 1954). Shopping orientations have been seen to be a reliable predictor of consumer patronage behaviour in retail formats such as catalog and mall shopping. Therefore it is expected that the study of shopping orientations can help retailers identify and understand those consumers who prefer to shop online and the reasons why.

Stone (1954) proposed the idea that shoppers can be classified based on their approach to shopping activities. He identified four types of shoppers-economic, personality, ethical and apathetic.

Economic shoppers would attempt to maximize their returns by carefully evaluating price, quality and value. This type of shoppers spends a considerable amount of time collecting information about the alternatives before making a purchase decision.

The personalizing shoppers build close relationship with the store personnel and make purchases close to home. For shoppers under this category, shopping at stores where they interact with salespeople and clerks on a personal level is important.

Ethical shoppers shop at stores in their immediate environment/neighbourhood with the objective of keeping the money within the community in order to perceive and build his community. He feels obligated to patronize local stores.

Apathetic shopper disdains shopping and would try and find ways to minimize the effect involved in completing a shopping activity.

In addition to the above orientations, other classifications for shoppers have been suggested. Bellenger and Korganonkar (1980) identified a socializing shopper as someone who views shopping as a social activity.

H<sub>2</sub>: Shopping orientation will have a significant effect on online shopping

### *Shopping Motivations*

In Technology Acceptance Model (TAM), the pre-assumed usefulness of an information system is to enhance job performance (Davis 1986). This emphasizes the pure utilitarian motivation for using a system. Shopping motivation answers the question "why do people shop?" (Tauber, 1972). Motivation is the driving force within individuals that force them into action (Schiffman and Kanuk, 2010). Gaining useful insights into shopping the reasons (motives) that make people go shopping (Ratneshwar, David and Cynthia, 2000) Shopping motivations includes:

Consumer shopping value is seen as the relationship between product and service quality and the price paid for the product (May, 1989). Michon and Chebat (2004) define shopping value as the aggregate gains that online shoppers obtain from a shopping trip and the degree of satisfaction with that experience.

Zeithmal (1988) defines value as "what I get for what I give".

Hedonic Shopping Value posits that peoples motives for shopping are a function of many variables, some of which are unrelated to the actual buying of products (Tauber, 1972). This means that an understanding of shopping motives require the consideration of satisfaction which shopping activities provide, as well as the utility obtained from the merchandise that may be purchased. Hedonic shopping predictors refers to aspects of consumer behaviours that relate to multisensory, fantasy and emotive aspects of consumption (Hirschman and Holbrook, 1982). This is to say, "people buy to shop and not shop to buy" (Babin, Darden and Graffin, 1994). Hedonic shoppers are intrinsically motivated towards shopping (Teller, Reutterer and Schnedlitz, 2008). For this group of shoppers, seeing, hearing, smelling and touching various products provide sensual enjoyment (Underhill, 1999)

Utilitarian shopping value approximates the classical economic model of consumer behaviour and depicts the buyer as a problem solver, rational and task-oriented (Babin, Dardin and Griffin, 1994). Utilitarian shoppers are extrinsically motivated and look for shopping experience and convenience that make their life more enjoyable and easier (Kin, 2002). For this group of shoppers, shopping is a work.

H<sub>3</sub>: Shopping motivation will have a significant effect on online shopping.

### *Normative Beliefs*

Normative beliefs are individuals beliefs about the extent to which other people who are important to them think they should or should not perform particular behaviours. Subjective norm or a predictor of intention to behave which in turn is a predictor of actual behaviour (Ajzen, 1991). Normative belief, according to Tsai (2009) reflects the pressure perceived by individuals to perform or not to perform a behaviour in relation to those persons or

organizations important to them. Emphasis on social pressure becomes relevant when it comes to customers doing something for the first time or something that is not in their specialty. Subjective norms capture the consumers perceptions of the influence of significant others (family, peers, authority figures and media). It is related to intention because people often act based on their perception of what others think they should be doing (Khan and Chavan, 2015).

H<sub>4</sub>: Normative Belief will have a significant relationship on online shopping.

#### *Past Experience*

The influence of past experience on consumers behaviour towards online shopping is an issue which has drawn much attention. Past research has found that online shopper with more internet related experience perceive less financial risk than those with less online experience (Miyazaki and Fernandez, 2001).

Studies have found that previous experience via a given shopping channel is negatively related to perceived risks associated with future purchase in that online shopping context, consumers who had positive experiences with online shopping, perceived more benefits and are willing to continue shopping online while those with

negative experience tend to neglect and speak ill of online stores. Ranganathan and Jha (2007) found that past online purchasing experience has a strong correlation with intention to purchase online. Knowing how past experience of buyers could affect purchasing behaviour is important for the developer of e-commerce application.

Past experience with online shopping is found to correlate positively with consumers likelihood to shop online. The more experienced consumers are with past online transaction experiences, the higher their purchases amounts and the more likely they are to be repeat purchasers and the lower likelihood of them aborting intended online transaction (Cho, 2014). These findings are supported by the extended technology Acceptance model which suggests that increased user experience has positive effect on users attitudes towards technology and the mastering of that technology (Venkatesh and Morris, 2000). Good experiences with returning items leads to repeat customers and recommendations for the retailer, while the bad experiences highlight hassles and the extra cost required.

H<sub>5</sub>: Past experience will have a significant effect on online shopping.

**Figure 1: Proposed Research Model**

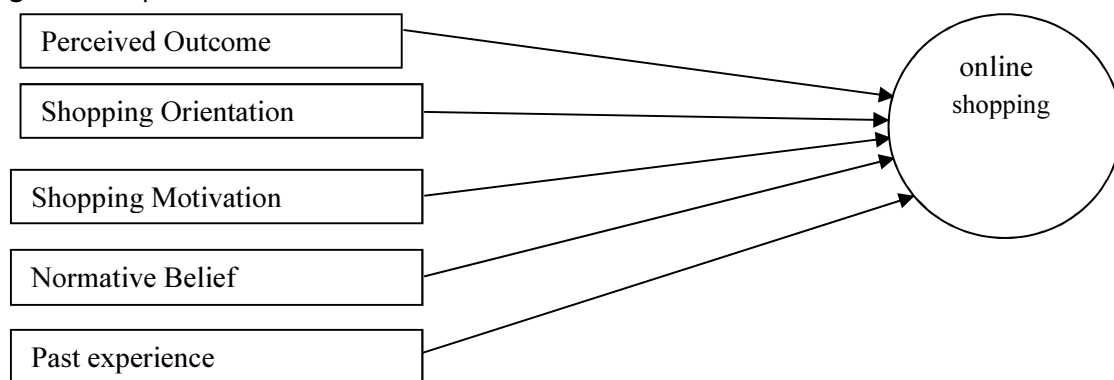

Source: Researchers' own conceptualization

#### **Methodology**

The research design adopted in this study is survey. The population of this study comprises

online shoppers in Anambra State. Thus, the population of this study is unknown (infinite) since the researcher cannot ascertain the

number of online shoppers in Anambra State. This study employed convenience sampling technique. This study made use of both primary and secondary data. Structured questionnaire was the major instrument for data collection. A total of 323 copies of questionnaire were

distributed out of which 311 copies were returned as correctly filled and usable. The data collected was analyzed using descriptive and inferential statistics. Multiple regression was used to test for the significance of five hypotheses generated for the study.

### Data presentation and Discussion of Findings

**Table 1:** Respondents Demographic Characteristics

Variable	Description	Frequency	Valid Percentage	Cumulative Percentage	Mean	Standard Deviation
Gender	Male	135	43.4	43.4	1.57	0.496
	Female	176	56.6	100		
	Total	311	100			
Age	18 - 30 years	261	83.9	83.9	1.16	0.368
	30 - 40 years	50	16.1	100		
	Total	311	100			
Educational Qualification	FSLC	2	0.6	0.6	3.29	1.026
	WAEC	94	30.2	30.9		
	OND/NCE	57	18.3	49.2		
	B.Sc	127	40.8	90.0		
	Postgraduate	31	10.0	100.0		
	Total	311	100			
Marital Status	Single	255	82.0	82.0	1.18	0.385
	Married	56	18.0	100		
	Total	311	100			

Source: Primary data, 2015

Table 1 above shows that majority of the respondents are female with a frequency of 176 (56.6%) while male constituted a frequency of 135 (43.4%) with a mean and standard deviation of 1.57 and 0.496 respectively. 83.9% of the respondents were between the ages of 18-30 years totaling 83.9% while the remaining 50 respondents (16.1%) fall between the ages of 30-40 years. The mean and standard deviation of the ages are 1.16 and 0.368 respectively. 0.6% of the respondents were holders of FSLC, 30.2%

were WAEC holders, OND/NCE holders were 18.3%, B.Sc holders were 40.8% while the Postgraduate holders were 10.0%. The mean and standard deviation of the educational qualifications of the respondents are 3.29 and 1.026 respectively. A large number of the respondents (255) with a percentage of 82.0% are single while 56 respondents (18.0%) are married. The mean and standard deviation of the responses are 1.18 and 0.385 respectively.

**Table 2:** Responses for how often Respondents shop online and the major internet store used.

Variable	Description	Frequency	Percent	Mean	Standard Deviation
How often do you shop online	Frequently	122	39.2	1.75	0.684
	Very often	43	13.8		
	Less often	146	46.9		

	Total	311	100		
Which of these e-stores have you used	Konga	80	25.7	2.19	1.086
	Jumia	150	48.2		
	OLX	44	14.1		
	Price Check	16	5.1		
	Others:	21	6.8		
	Dressrite				
	Kaymu etc				
Total	311	100			

Source: Primary data, 2015

Table 2 above shows that 122 (39.2%) of the respondents shop online frequently. 43 (13.81%) shop online very often and 146 (46.9%) shop online less often. The mean and standard deviation of these scores are 1.75 and 0.684 respectively. Also, 80 (25.7%) of the respondents shop on Konga, 150 (48.2%) shop on Jumia, 44 (14.1%) shop on OLX, 16 (5.1%) visit Price Check and only 21 (6.8%) shop on other sites like Dressrite, Kaymu etc.

Table 3 below shows the Beta coefficients which gives the contribution of each independent variable to the model while t-values and p-values revealed the effect of the variable and the critical ratio and the p-values respectively.

From Table 3 below, Perceived Outcome (.225>0.05), we therefore reject the hypothesis

and conclude that there is no significant relationship between perceived outcome and online shopping. Shopping Orientation (.020>0.05), we reject the hypothesis and conclude that there is no significant relationship between shopping orientation and online shopping. Shopping motivation (.757>0.05), we also reject the hypothesis and conclude that there is no significant relationship between shopping motivation and online shopping. Normative belief (.000<0.05), we accept the hypothesis and conclude that there is a significant relationship between normative belief and online shopping. Past Experience (.000<0.05), we also accept the hypothesis and conclude that a significant relationship exist between past experience and online shopping.

**Table 3:** Coefficients <sup>a</sup>

Model	Unstandardized coefficients		Standardized Coefficients Beta	T	Sig
	B	Std. Error			
1 (Constant)	4.094	.420		9.759	.000
Perceived outcome	-.085	.070	-.065	-1.215	.225
Shopping orientation	.117	.050	.128	2.330	.020
Shopping motivation	.016	.053	.018	.310	.757
Normative believe	.211	.057	.218	3.689	.000
Past experience	-.386	.070	-.314	-5.521	.000

Source : SPSS version 20. Dependent Variable: Online shopping

### Conclusions and Implications

Shopping Orientations and Shopping Motivations has no significant relationship with online shopping. This means that online shoppers are not moved by fun and excitement. Also, normative belief has a significant

relationship with online shopping. Online shoppers listen to the opinion of their friends, family and relatives and most times shop online to belong to the group of their friends who do so. Past experience also has a significant relationship with online shopping. Consumers



who continue shopping online have tried it once and enjoyed the process entirely. Thus, they continue. Perceived outcome was seen not to have any relationship with online shopping. Online consumers/shoppers in Anambra are not interested in the potential benefits and risks involved in online shopping.

The following recommendations are therefore made. Internet stores also should improve their e-WOM (i.e e-Word of mouth). This is because online shoppers more often listen to their family, friends and relations before shopping online. Online shoppers first/past experience with the e-stores to a large extent determine if they will continue with the act of internet shopping or switch to the conventional brick-and-mortar shopping. Therefore, e-stores should make this experience worthwhile for the online shoppers to ensure repeat e-purchase. Nevertheless, since online shoppers in Anambra state do not consider the benefits and risks involved in online shopping before going into it then e-stores should place less emphasis on the perceived benefits to be derived from online/shopping. More so, e-stores should enlighten Anambra

online shoppers on possible benefits to be derived from shopping online like convenience, time saving and so on. This can also serve as an added benefit. Strategies must be put in place to further increase access to the internet and draw investments into the telecommunications industry to not only fuel the success of e-commerce but also to boost the Nigerian economy. Online stores must be persistent in their efforts to create effective and relevant advertising campaigns about online shopping that appeal to Anambra populace and Nigerians at a whole. E-stores should seek new ways of delivering superior value to online shoppers.

Furthermore, this study is limited to the effect of consumer behavior on online shopping. Its effect on other internet activities like web browsing, emailing etc was not included. Further studies can incorporate internet activities as a whole so as to make it more elaborate. Finally, care must be taken in adopting the findings of this study. Further studies should include more variables of consumer behavior to see its effect on online shopping or internet activities as a whole.

## References

- Ajzen, I (1991). The theory of planned behaviour. *Organizational behaviour and human decision processes*, 50(2), 179-211
- Ayo, C.K, Ekong O.U, Fatudimu, I.T and Adebiji, A.A (2007); M-commerce implementation in Nigeria; Trends and issues journal of internet bank commerce, vol12(2) pp 1-5.
- Ayo, C.K; Adewoye, J.O and Oni, A.A (2011); Business-to-consumer e-commerce in Nigeria; prospects and challenges. *African journal of business management*, vol5(13), pp 5109-5717.
- Babin, B.J; Darden, W.R and Griffin .M.(1994). Work and/or fun : Measuring Hedonic and Utilitarian Shopping value. *Journal of Consumer Research*, vol 20(4), 644-656.
- Bellenger, D. N., and Korgaonkar, P.K (1980). Profiling the Recreational Shopper. *Journal of Retailing*. Vol. 56 pp 77-92.
- Chen, L. (2009). Online shopping behaviour: An empirical study based on theory of planned behaviour. Doctoral dissertation, University of Nebraska.
- Cho, J. (2004): Likelihood to abort an online transaction: Influences from cognitive evaluation, attitudes and behavioural Variables. *Journal of information and Management*. Vol. 41, 827 -838.
- Dave. C., Chadwick, F.E., Johnston, K. and Mayer. R., (2006). Internet marketing: strategy, Implementation and practice. Third Edition. Prentice Hall publishers.

- Davis, F. D. (1989). Perceived usefulness, perceived ease of use and user acceptance of information technology, *MIS Quarterly*. Vol. 13(3). Pp 319-340.
- Donthu, N and Gracia, A. (1999). The Internet shopper. *Journal of Advertising Research*. Vol. 39(3) pp 52-58.
- Forsythe, S.M and Shi, B. (2003). Consumer Patronage and Risk Perceptions in internet shopping. *Journal of Business research*, 56, PP.867-875.
- Geissler, G.L and Zinkhan, G.M (1998). Consumer perceptions of the world wide web: an exploratory study using focus group interviews. *Advances in consumer research*, 25(1), 386 – 392.
- Hirschman, E.C and Holbrook, M. B. (1982). Hedonic consumption: *Emerging Concepts, Methods and Propositions Journal of Marketing*, 46(3), 92-101.
- Internet live Stats (2010). Nigeria Internet Users. Retrieved March 10, 2015 from <http://www.internetlivestats.com/internetusers/nigeria/>
- Khan, M.A and Chavan, C.R (2015). Factors affecting online shoppers behavior of electronic goods purchasing in mumbai : An empirical Study. *International Journal in management and social sciences*, vol 3 (3), 467-476.
- Kin, Y. K (2002). Consumer Value: An Application to Mall and Internet Shopping. *International Journal of Retail and Distribution Management*, 30 (11/12). 595 – 602.
- Korgaonkar, P. K and Wolin, L. D. (1999). A Multivariate Analysis of Web Usage: *Journal of Advertising Research*, 39(2). PP 53-68.
- Liang, T. P and Lai, H. J (2002). Effect of store design on consumer purchases: An empirical study of online bookstores; An empirical study of onlinebookstores, *information and management* 39(6), 431-444.
- Li, N and Zhang. P (2002). Consumer online shopping attitudes and behavior; An assessment of research, Eight America conference on information systems.pp202-508.
- Li, H., Kuo, C. and Russel M.G, (1999). The Impact of Perceived Channel Utilities, Shopping Orientations and Demographics on the Consumers Online Buying Behaviour. *Journal of computer mediated communication*, vol 5(2).
- Limayem ,M., Khalifa. M and Frini, A. (2000).What makes consumers buy from internet? A Longitudinal Study of online shopping. *IEEE Transactions on systems, man and cybernetics- part A: Systems and Humans*. Vol 30 (4) , 421-432.
- May, E.G (1989). A retail Odyssey. *Journal of Retailing*, 65,356
- Michon, R. and Chebat, J. C. (2004). Cross Cultural Mail Shopping Values and Habitats. A Comparison Between English and French Speaking Canadians. *Journal of Business Research* 57, 883 -892
- Miyazaki A. D. and Fernandez; A. (2001) Consumer Perception of Privacy and Security Risk for Online Shopping. *The Journal of Consumer Affairs Vol 35, NO 1, 27 -44*.
- Philips Consulting (2014, July). Online Shopping Report : A study of current trends in online shopping in Nigeria. Retrieved August 30, 2015 from [www.philipsconsulting.net/images/files](http://www.philipsconsulting.net/images/files)
- Ranganathan, C. and Tha, S. (2007). Examining online purchase intentions in B2C e-commerce: integrating the human-computer interaction, behavioural and consumerist approaches. *Information Resources Management Journal*, 20, 48-64.
- Ratneshwar, S, David M. and Cynthia, H, (2000). The Role of Consumption, Contemporary Perspectives on Consumer Motives, Goals and Desires, New York: Routledge.

- Schiffman, L.G. and Kanuk, L. L. (2010) Consumer behaviour. New Jersey: Pearson.
- Solomon, M. (2010). Consumer Behavior: Buying, Having and Being. Pearson Publishers, 9<sup>th</sup> Edition.
- Stone, G. P. (1954). City and Urban Identification: Observation on the Social Psychology of City life. *American Journal of Sociology*. Vol. 60, 36-45
- Tauber, E. M. (1972). Why do people shop? *Journal of Marketing Management*, 36, 46-49.
- Teller, C., Reutterer, T. and Schnedlitz, P (2008) Hedonic and Utilitarian Shopper Types in Evolved and Created Retail, Agglomerations International Review of Retail, Distribution and Consumer Research, 18, 283 – 309.
- Tsai, C. C (2007). The relationship between internet perceptions and preferences towards internet based learning environment. *British Journal of educational technology*, 38(1), 167-170.
- Underhill P. (1999). Why we buy? *The Science of Shopping*. New York, N. Y. Simon Shuster.
- Venkatesh, V and Morris, M. G. (2000) Why don't men ever stop to ask for directions? Gender, Social Influence and their role in technology Acceptance and usage behavior. *MIS Quarterly*, vol. 24, no 1, 115 – 139.
- Xiao, B. and Benbasat, I. (2007). E-commerce product recommendation agent: use, characteristics and impact. *MIS Quarterly*, 31(1), 137 – 209.
- Zeithaml, V. (1988). Consumer Perception of Price, Quality and Value: A Means – end Model and Synthesis of Evidence. *Journal of Marketing*, 52, 2- 22.
- Zhou, L; Dai, L; and Zhang, D (2007). Online Shopping Acceptance Model: A critical survey of consumer factors in online shopping. *Journal of electronic commerce research*.vol.8 (10), pp 41-62.

# THE SUSTAINABLE DEVELOPMENT GOALS AND BUSINESS

Peter Jones, David Hillier and Daphne Comfort

## **Abstract:**

*The Sustainable Development Goals (SDGs) agreed at a United Nations General Assembly in 2015 embrace an ambitious and wide ranging set of global environmental, social and economic issues designed to effect a transition to a more sustainable future. The United Nations called on all governments to pursue these ambitious goals but also acknowledged the important role of the business community in addressing the SDG's. This paper offers a preliminary review of the efforts being made to encourage businesses, and more specifically the consumer goods industry, to address the SDGs and offers some wider reflections on the challenges business face in engaging with the SDGs.*

## **Introduction**

The Sustainable Development Goals (SDGs), agreed at a United Nations General Assembly in September 2015, were described as 'a plan of action for people, planet and prosperity' (United Nations 2015a). These goals are ambitious and embrace a wide range of environmental, social and economic issues including climate change, energy, water stewardship, marine conservation, biodiversity, poverty, food security, sustainable production and consumption, gender equality and economic growth. The United Nations called on all governments to develop national strategies to pursue the SDGs but also acknowledged 'the role of the diverse private sector ranging from micro-enterprises to cooperatives to multinationals' in addressing these goals. In reviewing future business engagement with the SDGs PricewaterhouseCoopers (2015) argued that when governments sign up to the SDGs 'they will look to society and business in particular for help to achieve them', that the SDGs 'will herald a major change for business' and that 'business

will need to assess its impact on the SDGs and review its strategy accordingly.' That said the Institute for Human Rights and Business (2015) suggested that 'the SDGs seem to have quietly re-imagined a new model of business, relapsed as an agent of development, harnessed and channelled by governments and set to work on alleviating poverty and fostering sustainable economic growth for all.' Further the Institute for Human Rights and Business (2015) argued that 'business is not an adjunct of aid' and that 'economic activity cannot easily be directed to where the need is greatest' but rather 'it prospers when provided with the right conditions and the right opportunities.' With this in mind this paper offers a preliminary review of international efforts being made to encourage businesses, and more specifically the consumer goods industry, to address the SDGs and offers some wider reflections on business engagement with the SDGs.

## **Sustainable Development Goals**

The SDGs have been described as demonstrating 'the scale and ambition' of the United Nations '2030 Agenda for Sustainable Development' which is designed to 'shift the

**Peter Jones** and **Daphne Comfort** work in the Business School at the University of Gloucestershire and **David Hillier** is an Emeritus Professor in the Centre for Police Sciences at the University of South Wales.

*world on to a sustainable and resilient path'* (United Nations 2015a). There are 17 SDGs, and 169 associated targets, in *'a genuinely comprehensive vision of the future'* in which *'little is left unaddressed'* from *'the wellbeing of every individual to the health of the planet, from infrastructure to institutions, from governance to green energy, peaceful societies to productive employment'* (Institute of Human Rights and Business 2015). The ratification of the SDGs is the latest in the line of global sustainable development initiatives which can be traced back to the declaration designed *'to inspire and guide the peoples of the world in the preservation and enhancement of the human environment'* (United Nations Environment Programme 1972) following the United Nations Conference on the Human Environment held in Stockholm in 1971. More recently the SDGs are seen to build on the United Nation's Millennium Development Goals (MDGs) established in 2001. The MDGs were described as having *'produced the most successful anti-poverty movement in history'* (United Nations 2015b) but other assessments of the achievements of the MDGs have been more balanced. . While Fehling et. al. (2013), for example, acknowledged that *'remarkable progress has been made'* they argued that *'progress across all MDGs has been limited and uneven across countries.'* At the same time the involvement of the business community in the MDGs was limited with PricewaterhouseCoopers (2015) commenting *'business, for the most part, didn't focus on the MDGs because they were aimed at developing countries.'*

There are some 17 SDG's (See Table 1) with each one having a number of associated targets. The targets for 2030 for Goal 1, namely to end poverty in all its forms everywhere include eradicating extreme poverty, measured as people living on \$1.25 per day, ensuring that all men and women and particularly the poor and vulnerable have equal rights to economic resources, access to basic services and

ownership and control over land and property; and building the resilience of the poor and vulnerable to reduce their exposure to climate change related extreme events. For Goal 6, namely to ensure availability and sustainable management of water and sanitation for all the 2030 targets include achieving universal and equitable access to safe and affordable drinking water for all: protecting and restoring water related ecosystems; and improving water quality by reducing pollution, eliminating dumping and minimising the release of hazardous chemicals. Targets for Goal 12, namely to ensure sustainable consumption and production patterns include achieving the sustainable management and efficient use of natural resources by 2030; halving per capital global food waste at the retail and consumer levels and reducing food losses along production and supply chains by 2030; and designing and implementing tools to monitor sustainable development impacts for sustainable tourism that creates jobs and promotes local culture and products.

### ***Promoting the SDGs within the Business Community***

THE SDGs are clearly wide ranging and ambitious and their successful promotion within the global business community seems likely to be a long and challenging journey. That said the Global Reporting Initiative (GRI), widely recognised as the leading global framework for sustainability reporting, along with the United Nations Global Compact (UNGC) and the World Business Council for Sustainable Development (wbcSD) have the *'SDG Compass'* which offers a *'guide for business action on the SDGs'* that is designed to *'assist companies in maximizing their contribution to the SDGs'* (GRI/UNGC/wbcSD 2015). This guide includes *'five steps'* (GRI/UNGC/wbcSD 2015) namely

- *Understanding the business case*
- *Defining priorities*
- *Setting goals*

- *Integrating and*
- *Reporting and communicating*

While the guide has been developed principally for large multinational corporations it is also seen to provide a valuable resource for small and medium sized enterprises and to be applicable to all business sectors.

In making the case for business engagement with the SDGs PricewaterhouseCoopers (2015) argued that *'increasingly companies from all sectors are having to confront and adapt to a range of disruptive forces including globalisation, increased urbanisation, intense competition for raw materials and natural resources and a revolution in technology that is challenging the business models of many sectors while forcing all companies to be more accountable to, and transparent with, all their stakeholders.'* In introducing their *'guide for business action on the SDGs'* the Global Reporting Initiative/United Nations Global Compact/World Business Council for Sustainable Development (2015) argued *'as the SDGs form the global agenda for the development of our societies, they will allow leading companies to demonstrate how their business helps to advance sustainable development, both by minimizing negative impacts and maximizing positive impacts on people and the planet.'* Further PricewaterhouseCoopers (2015) emphasised its belief that *'when global companies align with the SDGs they will have a clearer view on how their business helps or hinders a government to achieve its goals, and the opportunity to evidence and maintain their licence to operate'* and that such companies will *'have a competitive advantage over those companies who don't understand their contribution or use their knowledge to revise their strategies accordingly.'*

More specifically (GRI/UNGC/wbcsd 2015) suggested that companies that look to employ the SDGs as a framework to shape and report their strategies will be able to realise a number of benefits namely

- *Identifying future business opportunities*
- *Enhancing the value of corporate sustainability*
- *Strengthening stakeholder relations and keeping pace with policy developments*
- *Stabilising societies and markets and*
- *Using a common language and shared purpose*

In identifying business opportunities, for example, the arguments are that sustainable development challenges are presenting market opportunities for companies to develop innovative energy efficient technologies, to reduce greenhouse gas emissions and waste and to meet the needs of largely untapped markets for health care, education, finance and communication products and services in less developed economies. By enhancing the value of corporate sustainability, and more specifically by integrating sustainability across the value chain, it is argued that companies can protect and create value for themselves by increasing sales, developing new markets, strengthening its brands, improving operational efficiency and enhancing employee loyalty and reducing staff turnover. It is also argued that companies that work to advance the SDGs will improve trust amongst their stakeholders, reduce regulatory and legal risks and build resilience to future cost increases and regulatory and legislative requirements.

The focus on defining priorities encourages companies to adopt a strategic approach in assessing their current and possible future impacts on the SDGs with the focus being on looking to enhance positive impacts and to reduce negative impacts. In making such an assessment companies are advised to map the SDGs against their value chain and to engage with both internal and external stakeholders and particularly to give due attention to future impacts on the environment and to disadvantaged and marginalized groups. The guide argued that mapping the high impact



areas will help a company to determine its priorities, to select appropriate business indicators to measure these impacts and to put the necessary data collection processes in place. The third step in the guide involves *'setting specific measurable and time-bound sustainability goals'* (GRI/UNGC/wbcsd 2015) and here the accent is seen to be on the selection of key performance indicators to drive, monitor and communicate a company's progress against its strategic goals. The guide also recommends that companies adopt high levels of ambition that will, in turn, *'spur innovation and creativity'* (GRI/UNGC/wbcsd 2015). Companies are also advised to announce their commitment to the SDGs on the United Nations business website.

The fourth step emphasises the need for companies to integrate sustainability into their core business across the whole of the supply chain. This is seen to involve ownership of, and commitment to sustainability goals throughout the company and clear communication of how these sustainability goals are contributing to wider business goals. The guide stresses the importance of embedding sustainability across all functions, though it recognises that some functions will be more important than others, and it applauds those companies which have established cross-functional sustainability boards or task forces and the establishment of sustainability committees at board level. Finally the guide highlights the importance of transparent reporting and communication mechanisms and of corporate sustainability disclosure. The development of systems designed to integrate the management of sustainability into strategic decision making is seen to be essential as is the need to adopt internationally recognised sustainability reporting standards. Here the SDGs are seen to provide a common language for sustainability reporting both within and across companies.

### ***The SDGs and the Food, Drinks and Consumer Goods Sector.***

While the SDGs have potentially major implications for all sectors of the global economy in many ways the food, drinks and consumer goods sector is at the heart of the drive towards a more sustainable future and is undoubtedly in a position to drive sustainability goals. The Sustainability Consortium (2016), for example, recognised that while *'consumer goods bring countless benefits to society, dramatically improving lifestyles around the world'* it also reported that consumer goods account for 60% of greenhouse gas emissions, 80% of water withdrawals, 20% of industrial water pollution and 75% of forced and child labour. At the same time *'retailers have come to assume a pivotal role in responding to the sustainability requirements faced by consumer goods in general and more specifically by food and drinks products.'* Here retailers, as the active intermediaries between producers and consumers, can be seen to be in a powerful position to drive more sustainable production and consumption through their partnerships with suppliers and through their regular, often daily, contact with consumers.

The Consumer Goods Forum, a global network of over 400 retailers, manufacturers and service providers which provides a platform on a number of strategic issues including sustainability, has argued that its work is directly related to ten of the SDGs (namely Goals 1, 2, 3, 5, 6, 8, 12, 13, 15 and 17 as in Table 1). In addressing Goal 2, for example, the Consumer Goods Forum stressed its *'commitment to making public company policies on nutrition and product formulation and industry-wide implementation of consistent product labelling and consumer information to help consumers to make informed choices and usages'* (The Consumer Goods Forum 2105). In reviewing taking urgent action to combat climate change and its impacts the Consumer Goods Forum drew attention to its *'environmental*

*sustainability work*' and to *'approved resolutions to begin phasing out HFCs from 2015, to achieve zero-net deforestation by 2010 and halve food waste by 2025, thus tackling three of the most material climate impacts facing the consumer goods industry globally.'* The Consumer Goods Forum also reported that its commitment to protect the planet focused on the sustainable sourcing of soya, palm oil, beef, paper and pulp.

More specifically the UNGC and KPMG have published the *'SGD Matrix'* for the food, beverage and consumer goods industry which *'profiles some of the most significant opportunities, principles-based initiatives and collaborations for the Food, Beverage and Consumer Goods Industry'* (UNGC and KPMG). The matrix looks to group what it describes as *'the biggest opportunities for shared value-i.e. where we see the coming together of market potential, societal demands and policy action'* as being grouped around four specific themes. Namely enterprise development; sustainable supply; healthy and sustainable living; and product innovation. In addressing enterprise development, for example, the aim is to promote inclusive development by increasing the participation of small and medium size business in developing economies which is seen to include providing training and best practice guides, connecting small businesses and entrepreneurs to capital and creating markets for local products through innovation and mobile technology. The theme of sustainable supply is focused on reducing climate change impacts through a range of initiatives including reductions in natural resource usage, increasing the use of renewable sources of energy, monitoring and reducing food waste and enhancing climate resilience across supply chains.

The Matrix addresses each of the 17 SDG goals. In examining Goal 2 namely ending hunger, achieving food security and improved nutrition and promoting sustainable agriculture, for example, a number of initiatives are outlined.

Here the importance of companies collaborating with farmers, food processors and traders to increase productivity, storage, logistics and market efficiency is emphasised which it is claimed will *'empower them to enter/remain in the company's value chain by producing high quality, safe and nutritious foods at competitive prices'* (UNGC and KPMG 2016). Companies are also encouraged to *'leverage the power of mobile networks to provide farmers with real time access to markets and mobile payments, particularly in areas that lack a formal banking structure'* (UNGC and KPMG 2016). Illustrative examples for a number of companies, including Diageo, Nestle, Heineken, Unilever and Starbucks, which are said to be *'leading by example'* (UNGC and KPMG 2016). Here, for example, Nestlé's 2014 commitment on land and land rights in agricultural supply chains and its adoption of the Food and Agriculture Organization's voluntary guidelines on the responsible governance of tenure of land, fisheries and forests is seen to be crucial in helping the landless gain access to land.

In looking to ensure sustainable consumption and production patterns (Goal 12) the matrix identifies a number of opportunities for shared value. These opportunities include striving to phase out hydrofluorocarbons and derivative chemical refrigerants and replacing them with natural refrigerants; increasing energy efficiency across the value chain; reducing packaging and increasing the recycling of end products and by-products of the production process; and raising consumer awareness of the importance of sustainable consumption and practical steps that can promote sustainably. Here again a number of illustrative examples are cited in an attempt to demonstrate how companies are promoting sustainable consumption and production. It is reported, for example, that Heineken has set a number of targets to reduce carbon dioxide emissions across the value chain namely a 40% reduction in emissions in production, a 50% reduction in

emissions from fridges and a 29% reduction in emissions in distribution in Europe and the Americas. The Lego Group is reported to be exploring new ways of increasing the recycling of its packaging materials by targeting each stage in the supply chain.

### **Discussion**

The SDG's are undoubtedly an ambitious and a wide ranging agenda and their vision of a truly sustainable future faces a number of major challenges. In providing a briefing for UK Members of Parliament, for example, Lunn et. al. (2015) expressed concerns that the SDGs are not legally binding and thus *'successful implementation therefore depends entirely on political commitment'*, that implementation may fall well short of a truly transformational agenda and that the cost of the SDGs will considerably exceed the current global development and aid budget. At the same time Lunn et. al. (2015) also questioned the robustness of the monitoring, accountability and follow up mechanism, if there would be genuine ownership of the SDGs and arguably more critically if the chosen goals and targets are the correct ones. While the business community is being encouraged to contribute to the realisation of the SDGs a number of issues merit reflection and discussion.

While the headline call for greater business engagement with the SDGs can be seen as a rallying cry it masks underlying complexities and tensions. The Institute for Human Rights and Business (2015), for example, argued that the inclusion of businesses in global sustainable development is complex in that *'it assumes companies of all different sizes and all different sectors will increasingly operate according to environmental, social and human rights standards..... it assumes business models will be reconfigured as necessary to ensure sustainability of products and services, sometimes at the expense of higher profits'* and *'it assumes that the business community, in partnership with states and civil society, will*

*channel a greater share of resources towards meeting SDG targets, through investment as well as philanthropy.'*

Such massive hurdles aside where businesses look to develop a genuine sense of engagement with the SDGs they face major challenges in determining which of the 17 SDGs (and which of the 169 associated targets) they select and prioritise and how they integrate SDGs into their existing corporate sustainability strategies. The vast majority of large companies employ a range of stakeholder engagement processes to determine the material issues, namely the explicit identification and prioritization of the environmental, social and economic issues which underpin a company's sustainability strategy. Within this selection and prioritisation process there is a generic issue concerning the nature of the relationship between company interests and stakeholder interests. Where a company, and more specifically its executive management team, is principally, and sometimes exclusively, responsible for identifying and determining material issues, such issues seem more likely to reflect strategic corporate goals rather than the SDG's. Bannerjee (2008) argued that *'despite their emancipatory rhetoric, discourses of corporate citizenship, social responsibility and sustainability are defined by narrow business interests and serve to curtail the interests of external stakeholders.* As such the successful progressive adoption of the SDG's may require a fundamental change in corporate culture but as Fernando (2003) argued *'capitalism has shown remarkable creativity and power by appropriating the languages and practices of sustainable development.'*

PricewaterhouseCoopers (2015), for example, suggested that self-interest may drive SGD selection and businesses may be *'set to cherry pick the SDGs.'* In addressing the former PricewaterhouseCoopers (2015) argued that in the SDG selection process businesses will *'see their greatest impact and opportunity in areas that will help drive their own business growth.'*

Further PricewaterhouseCoopers (2015) argued that *'when business profits from solving social problems, when it makes profit while benefitting society and business performance simultaneously, it creates solutions that are scalable'* and asks *'should we question the motives of business if their activity and ingenuity works in the benefit of society.'* In addressing cherry picking the SDGs PricewaterhouseCoopers (2015) argued that *'it's clear that business doesn't intend to assess its impact across all the SDGs, its plan is to look at those relevant to their business or a sub set of these. It's less about picking the easiest, most obvious or positive ones and more about picking the ones that are material to the business.'* These suggestions certainly strike a chord with the concept of creating shared value developed by Porter and Kramer (2011) defined as *'policies and practices that enhance the competitiveness of a company while simultaneously addressing the economic and social conditions in the communities in which it operates'* but here again such an approach might be seen by some commentators to fall well short of the underlying ethos of the SDGs.

Where individual companies identify and pursue a sustainability strategy that is integrated into the SDGs they will then also need to measure their achievements and to integrate their achievements into their sustainability reporting process. van Wensen et. al. (2011) defined sustainability reporting as *'the provision of environmental, social and governance information within documents such as annual reports and sustainability reports.'* The *SDG Compass*, for example, emphasised to companies that *'It is important to report and communicate on your progress against the SDG's continuously in order to understand and meet the needs of your stakeholders'* (GRI/UNGC/wbcSD 2015). In some ways sustainability reporting has become an 'industry' in itself and a number of private companies and voluntary organisations offer sustainability

reporting services and frameworks. The United Nations Environment Programme (2013), for example, identified a number of *'reporting frameworks and protocols, reporting systems, standards and guidelines'* but reported that the Global Reporting Initiative *'has become the leading global framework for sustainability reporting'* and cited its comprehensive scope, its commitment to continuous improvement and its consensus approach as being important in contributing to its pre-eminence in the field. Originally founded in 1997 the Global Reporting Initiative reporting framework has progressively evolved from the original G1 Guidelines launched in 2000 to the current G4 Guidelines introduced in 2013. The external assurance of sustainability reports is seen to be of central importance within the new guidelines.

While many large companies currently claim that their sustainability reports follow GRI G4 guidelines their approach to independent external assurance is often limited and/or confined solely to carbon emissions data. While this is currently not a problem *per se* as sustainability reports are themselves voluntary and accompanying assurance statements are not subject to statutory regulation, the lack of comprehensive independent assurance can be seen to undermine the credibility and integrity of the sustainability reporting process. However for large companies capturing and aggregating data on a wide range of environmental, social and economic issues, across a wide range of business activities throughout the supply chain and in a variety of geographical locations and then providing access to allow external assurance is a challenging and potentially very costly venture. It is also one which many companies currently choose not to pursue. In looking to the future if companies are to publicly demonstrate and measure their commitment and contribution to the SDGs then the independent assurance of all the data included in sustainability reports would seem to be

essential. That said in providing guidance on *'effective reporting and communication'* the *'SDG Compass'* simply notes *'companies can make use of competent and independent external assurance as a way to enhance the credibility and quality of their reports'* (GRI/UNGC/wbcsd 2015).

There are fundamental concerns about the underlying tensions between sustainability and economic growth and more pointedly about whether continuing economic growth is compatible with sustainable development. Some critics would suggest that continuing economic growth and consumption, dependent as it is, on the seemingly ever increasing depletion of the earth's natural resources is fundamentally incompatible with sustainability. Higgins (2013, webpage), for example argued *'the economic growth we know today is diametrically opposed to the sustainability of our planet.'* However In outlining its agenda for the SDGs the United Nations (2015a) argued *'sustained, inclusive and sustainable economic growth is essential for prosperity'* but failed to define the term sustainable economic growth or to explicitly recognise the environmental impacts and consequences of continuing economic growth. In an arguably more measured approach the *'SDG Compass'* argued that *'companies will discover new growth opportunities'* whilst ensuring that *'the global economy operates safely within the capacity of the planet to supply essential resources such as water, fertile soil, metals and minerals thereby sustaining the natural resources that companies depend on for production'* (GRI/UNGC/wbcsd 2015) but there is no treatment of if, and how, this complex equation might be resolved.

Innovation, particularly technological innovation, is widely seen to offer an important means of increasing production efficiency. The *'SDG Compass'*, for example, stressed the importance of harnessing *'innovative technologies to*

*increase energy efficiency, renewable energy, storage storage, green buildings, and sustainable transportation'* and of substituting *'traditionally manufactured and processed products by ICT and other technological solutions that reduce emissions and waste'*(GRI/UNGC/wbcsd 2015). However Huesemann (2003) argued that *'improvements in technological eco-efficiency alone will be insufficient to bring about the transition to sustainability.'* More generally Schor (2005) argued that *'the popularity of technological solutions is also attributable to the fact that they are apolitical and do not challenge the macrostructures of production and consumption'* and that *'they fail to address increases in the scale of production and consumption, sometimes even arguing that such increases are unsustainable if enough natural-capital-saving technical change occurs.'*

The concept of sustainable consumption, which Cohen (2005) has described as *'the most obdurate challenge for the sustainable development agenda'* can be seen to provide a particularly daunting challenge for companies, and perhaps particularly for retailers, which want to engage with the SDGs. In addressing goal 12 namely to *'ensure sustainable consumption and production patterns'* the United Nations Development Programme (2016) stressed the need to *'urgently reduce our ecological footprint by changing the way we produce goods and services.'* That said within many developed economies there is little consumer appetite for sustainable consumption and here the European Commission's (2012, p.9) recognition that *'sustainable consumption is seen by some as a reversal of progress towards greater quality of life'* in that *'it would involve a sacrifice of our current, tangible needs and desires in the name of an uncertain future'* resonates. This view is supported by Reisch et. al. (2008) who argued that although moving towards sustainable consumption is a major policy agenda, *'growth of income and material*



*throughput by means of industrialization and mass consumerism remains the basic aim of western democracy.'* The 'SDG Compass' couched its guidance to companies on sustainable consumption and production in terms of shared value and stressed the overall importance of energy efficiency and waste reduction strategies, for example, rather than a more explicit and measurable focus on reducing corporate or individual ecological foot prints.

### **Conclusion**

The SDGs offer an ambitious and wide ranging global vision for a sustainable future. While the transition to such a future demands

commitments from governments and all sections of society as well as universal changes in mind-sets and behaviours, the United Nations has called on businesses to play a central role in achieving the SDG's. Here the underlying aim is to connect business strategies to global priorities for people and the planet. If the business community is to play its part in the transition to a sustainable global future then it faces a wide range of fundamental challenges. How businesses address and respond to those challenges will ultimately surely determine the success or failure of the SDGs.

**TABLE 1: THE SUSTAINABLE DEVELOPMENT GOALS**

1. End poverty in all its forms everywhere
2. End hunger, achieve food security and improved nutrition and promote sustainable agriculture
3. Ensure healthy lives and promote well-being for all at all ages
4. Ensure inclusive and equitable quality education and promote lifelong learning opportunities for all
5. Achieve gender equality and empower all women and girls
6. Ensure availability and sustainable management of water and sanitation for all
7. Ensure access to affordable, reliable, sustainable and modern energy for all
8. Promote sustained, inclusive and sustainable economic growth, full and productive employment and decent work for all
9. Build resilient infrastructure, promote inclusive and sustainable industrialization and foster innovation
10. Reduce inequality within and among countries
11. Make cities and human settlements inclusive, safe, resilient and sustainable
12. Ensure sustainable consumption and production patterns
13. Take urgent action to combat climate change and its impacts
14. Conserve and sustainably use the oceans, seas and marine resources for sustainable development
15. Protect, restore and promote sustainable use of terrestrial ecosystems, sustainably manage forests, combat desertification, and halt and reverse land degradation and halt biodiversity loss
16. Promote peaceful and inclusive societies for sustainable development, provide access to justice for all and build effective, accountable and inclusive institutions at all levels
17. Strengthen the means of implementation and revitalize the global partnership for sustainable development



## REFERENCES

- Banerjee, S. B. (2008) Corporate Social Responsibility: The Good, the Bad and the Ugly, *Critical Sociology*, 34(1), 51-79
- Cohen, M.J. (2005) 'Sustainable consumption in a national context; an introduction to the symposium', <http://ejournal.nbii.org/archives/vol1iss1/0410-008.cohen.html> (Accessed 16 November 2015)
- Consumer Goods Forum (2015) 'The consumer Goods Forum and the Sustainable Development Goals', <http://www.theconsumergoodsforum.com/files/Publications/SDG-Cogs.pdf> (Accessed 14 June 2016)
- European Commission (2012) 'Policies to Encourage Sustainable Consumption', [http://ec.europa.eu/environment/archives/eussd/pdf/report\\_22082012.pdf](http://ec.europa.eu/environment/archives/eussd/pdf/report_22082012.pdf) (Accessed 3 February 2016)
- Fehling, M., Nelson, B. and Venkatapuram, S. (2013) 'Limitations of the Millennium Development Goals; A Literature Review', *Public Health*, Vol. 8, No. 10, pp. 1109-1122
- Fernando, J.L. (2003) 'Rethinking Sustainable Development', *The Annals of the American Academy of Political and Social Science*, Sage Publications, London, <http://www.sagepub.com/booksProdDesc.nav?currTree=Subjects&level1=B00&prodId=Book227408> (Accessed 15 March 2014)
- Global Reporting Initiative/United Nations Global Compact/wbcsd (2015) '*SDG Compass: The guide for business action on the SDG's*', <https://www.globalreporting.org/resource/library/qssb/Item%2029%20-%20SDG%20Compass.pdf> (Accessed 17 June 2016)
- Higgins, K.L. (2013) 'Economic growth and sustainability- are they mutually exclusive', <https://www.elsevier.com/connect/economic-growth-and-sustainability-are-they-mutually-exclusive> (Accessed 28 May 2016)
- Huesemann, M.H. (2003) 'The limits of technological solutions to sustainable development', <http://dub.thayer.dartmouth.edu/~d30345d/courses/engs171/Limits-to-Sustainability.pdf> (Accessed 15 April 2014)
- Institute for Human Rights and Business (2015) 'State of Play- Business and the Sustainable Development goals: Mind the Gap – Challenges for Implementation', [http://www.ihrb.org/media/images/reports/state\\_of\\_play\\_report-business\\_and\\_the\\_sdgs.pdf](http://www.ihrb.org/media/images/reports/state_of_play_report-business_and_the_sdgs.pdf) (Accessed 28 May 2016)
- Lunn, J., Downing, E. and Booth, L. (2015) 'The Sustainable Development Goals and the post-2015 development agenda', House of commons Briefing Paper No. 7291, <HTTP://RESEARCHBRIEFINGS.FILES.PARLIAMENT.UK/DOCUMENTS/CBP-7291/CBP-7291.PDF> (Accessed 12 June 2016)
- Porter. M. E. and Kramer, M. R. (2011) 'Strategy and society: the link between competitive advantage and corporate social responsibility', *Harvard Business Review* Vol. 87, pp. 78-92
- PricewaterhouseCoopers (2015) 'Making It Your Business; Engaging with the sustainable Development Goals', [https://www.pwc.com/gx/en/sustainability/SDG/SDG%20Research\\_FINAL.pdf](https://www.pwc.com/gx/en/sustainability/SDG/SDG%20Research_FINAL.pdf) (Accessed 28 May 2016)
- Reisch, L., Spash, C. L. and Bietz, S. (2008) Sustainable Consumption and Mass Communication: A German Experiment', <http://www.csiro.au/files/files/pm9m.pdf> (Accessed 23 March 2014)
- Schor, J. B. (2005) 'Prices and quantities: unsustainable consumption and the global economy', *Ecological Economics*, Vol. 55, pp.309-320, <http://www.sciencedirect.com/science/article/pi>

[i/S0921800905003204#](#) (Accessed 27 November 2013)

The Sustainability Consortium (2016) 'Greening Global Supply Chains: From Blind Spots to Hot Spots to Action', <https://www.sustainabilityconsortium.org/wp-content/2016-impact-report.php> (Accessed 3 June 2016)

United Nations (2015b) 'The Millennium Development Goals Report 2015' [http://www.un.org/millenniumgoals/2015\\_MDG\\_Report/pdf/MDG%202015%20rev%20\(July%201\).pdf](http://www.un.org/millenniumgoals/2015_MDG_Report/pdf/MDG%202015%20rev%20(July%201).pdf) (Accessed 3 June 2016)

United Nations (2015a) 'Transforming Our World: The 2030 Agenda for Sustainable Development', <https://sustainabledevelopment.un.org/content/documents/21252030%20Agenda%20for%20Sustainable%20Development%20web.pdf> (Accessed 3 June 2016)

United Nations Development Programme (2016) 'Goal 12: Responsible Production and Consumption', <http://www.undp.org/content/undp/en/home/sdgoverview/post-2015-development-agenda/goal-12.html>, (Accessed 3 June 2016)

United Nations Environment Programme (1972) 'Declaration of the United Nations Conference on the Human Environment', <http://www.unep.org/documents.multilingual/default.asp?documentid=97&articleid=1503> (Accessed 3 June 2016)

United Nations Environment Programme (2013) 'Frequently Asked Questions on Corporate Sustainability Reporting', <https://www.globalreporting.org/resourcelibrary/GoF47Para47-FAQs.pdf> (Accessed 4 April 2016)

United Nations Global Compact and KPMG (2016) 'SDG Industry Matrix; Food, Beverages and Consumer Goods', <https://www.unglobalcompact.org/library/3961> (Accessed 28 May 2016).

van Wensen, K., Broer, W., Klein, J. and Knopf, J. (2011) 'The state of Play in Sustainability Reporting in the European Union', <http://www.google.co.uk/url?sa=t&rct=j&q=&esrc=s&source=web&cd=1&cad=rja&uact=8&ved=0ahUKEwi16ea4so7OAhUJcAKHZZPDecQFggjMAA&url=http%3A%2F%2Fec.europa.eu%2Fsocial%2FBlobServlet%3FdocId%3D6727%26langId%3Den&usq=AFQjCNH7vcEDcrlAbs6LD3aIF6Sk8MHSJA>

# A COMPREHENSIVE PERSPECTIVE ON MEDICAL TOURISM CONTEXT AND A CREATION OF THE CONCEPTUAL FRAMEWORK

Masoud lajevardi

## **Abstract:**

*This study developed a theoretical structural model to examine the influence of motivational factor and perceived destination image in the perceived service quality and overall satisfaction of medical tourists who have travelled to a foreign country to obtain a medical treatment. The theory of motivation, perception was combined in this research. This study included customer perceptions based on motivational factor, destination image, quality, value, and satisfaction which occurred after the medical trips. This is a quantitative study and survey method is used to collect data. The instrument of this study is developed based on the review of previous literature. There were only 260 completed responses that met all the required criteria. After data collection was completed, the Statistical Package for Social Sciences (SPSS) and SPSS AMOS 22.0 will be used to analyze and interpret the result. The results show that there were positive impact of Destination Image and Motivational Factor on Perceived Value, and positive impact of Perceived Value on Overall Satisfaction. Once again, it can be confirmed that Destination Image has the strongest impact on Perceived Quality, illustrated by the highest standardized value of .473.*

**Key words:** *medical tourism, motivational factor, perceived destination image, perceived service quality*

## **Introduction**

Medical tourism as a niche has emerged from the rapid growth of what has become an industry, where people travel often long distances to overseas countries to obtain medical, dental and surgical care while simultaneously being holidaymakers, in a more conventional sense. Medical tourism is becoming an increasingly popular option for patients looking to access procedures (typically via out-of-pocket payment) that are seemingly unavailable to them in their home countries due to lack of affordability, lack of availability, and/or

lengthy waiting lists, among other reasons (Ackerman, 2007). People wishing to access procedures such as cardiac, orthopedic, dental, and plastic surgeries are going to key destination countries known to provide care for international patients (Al-Hinai et.al, 2011). Medical tourism enables patients to quickly and conveniently receive medical services through travel, at lower prices and, oftentimes, at better quality than they could in their native countries. The reasons patients travel for treatment vary. For example, In Canada, people are frustrated by long waiting lines. In Great Britain, patients cannot wait for treatment by the National Health

**Masoud lajevardi** is a PHD student in marketing management, Department of Management, Semnan Branch, Islamic Azad University, Semnan, Iran. E-mail: lajevardi\_masoud@yahoo.com

Service; nor can they afford to see a physician in private practice. (Allemanet.al, 2011)

Medical tourism combines medicine with tourism, encouraging patients to seek medical services while traveling for relaxation and leisure and have emerged as one of the fastest growing areas of academic research interest in both tourism and health studies (Balaban and Marano, 2010; Crooks et al., 2010; Underwood and Makadon, 2010;Whittaker, 2008). Smith and Puczko (2009) argue that health tourism is composed of medical tourism and wellness tourism, meaning that medical tourism is a subset of health tourism. Borman (2004) and Jonathan (1994) define health tourism as attracting tourists with the unique attractions of the destination combined with facilities for healthcare services. Connell (2006) points out that a distinction must be made between health tourism and medical tourism, whereby medical tourism is the correct term to use in cases in which medical interventions are required. Medical tourism involves not only going overseas for medical treatment, but also the search for destinations that have the most technical proficiency and which provide it at the most competitive prices (Augé, 1995). The degree of synthesis between medical services and tourism is also significant, in that medical tourism's fundamental characteristic is its combination of medical services and the tourism industry. As a result, the degree of synthesis between these two areas should be taken into consideration when defining medical tourism. However, some researchers in medical journals state that medical tourism includes only medical services, rather than tourism services (Bagheri, 2010). Within the health tourism arena, medical tourism is among the fastest growing sectors, and many countries are now making legal and practical plans to serve it reduced transportation costs, higher incomes, knowledge and technology transfer, and competitive prices all favor travel to distant countries for medical reasons. One of the fastest growing tourism

markets in the world, medical tourism now generates US\$60 billion in business annually worldwide (Bell et.al, 2011), and the number of countries offering state-of the- art medical facilities and services to foreign tourists is on the increase. This international trade in medical services also has huge economic potential for the global economy (Bookman & Bookman, 2007), and medical tourism is emerging as a particularly lucrative sector for developing countries.

Many countries have seized the business opportunities that medical tourism offers. In 2005, for example, India, Malaysia, Singapore, and Thailand attracted more than two and a half million medical tourists (Brown, 2008). Colombia, Singapore, India, Thailand, Brunei, Cuba, Hong Kong, Hungary, Jordan, Lithuania, Malaysia, the Philippines, and the United Arab Emirates have emerged as major healthcare destinations, and Argentina, Bolivia, Brazil, Costa Rica, Mexico, and Turkey are also in the process of making themselves attractive such destinations, particularly in the area of cosmetic surgery (Buzinde, 2012). At present, Asia constitutes the most important medical tourism region. Horowitz and Rosenweig (2007) has summarized that major reasons for seeking medical tourism are (1) low cost, (2) avoid waiting lists, (3) procedure not available in home country, (4) tourism and vacations, (5) privacy and confidentiality. While people from less developed countries have often visited, and continue to visit, developed countries such as US and UK to avail of cutting –edge medical facilities and highly skilled physicians, this trend began to reverse in the 1990s and the term medical tourism came to refer to people from developed countries travelling to emerging economies with the intention of combining health care with holidaying. With the aging population demographic in developed countries that increases demand, and the shortage of trained doctors (Carrera and Bridges , 2006), leading to increasing health care costs results in an

unfulfilled demand for medical services, a gap occurs, one that several countries seek to fill. According to World Health Organization (WHO), in 2000, U.S. spent 13.2 percent of the GDP on its health care, by the 2007 this went up to 15.7 percent (WHO, 2010), and is estimated to be 19.3% by 2019. Asia, widely considered the region with the most potential in the world medical tourism market, generated \$3.4 billion in revenue in 2007 through medical tourism. Asia's revenues have increased annually by more than 20%, and are expected to total \$4.4 billion by 2012. In 2003, approximately 350,000 patients from industrialized nations traveled to less developed countries for healthcare. It is projected that 750,000 Americans will go offshore for medical care in 2007. Medical tourism in Asia is currently generating US\$ 1.3 billion in revenue and is expected to grow to US\$ 4.4 billion by 2012. In today's highly global competitive environment, a number of countries, such as Belarus, Latvia, Lithuania, Costa Rica, India, Malaysia, Singapore and Thailand, have responded to the opportunities offered by medical tourism to provide cross-border medical care for international visitors (Chee, 2010). In India Medical tourism is one of the fastest growing subsectors of its industries. Surgical procedures that can cost hundreds of thousands of dollars in the USA can be had at a fraction of the cost in India. The total healthcare market in India is expected to increase its contribution to GDP from 5.2 percent at present to 8.5 percent over the next ten years News from India Tourism Report (2010). Connell 2006 state that, India advertises itself as the global center of medical tourism by offering everything from alternative Ayurveda therapy to coronary bypasses and cosmetic surgery. Travel companies in India are also cooperating with hospitals to facilitate travel by arranging phone consultations with doctors to help foreign patients save time and money once they get to India. Thailand has the longest history; it became notable as a destination for medical tourism as

early as the 1970s when the medical tourism profession began to specialize in sex change operations; later they moved to cosmetic surgery. Medical tourism in Thailand is now a prosperous industry. In 2007, as many as 1.4 million visitors arrived in Thailand seeking medical care; the Health Ministry expects the number of medical tourists to surpass two million by 2012 Report from Airline & Travel News (2009). To build brands in the healthcare industry, leading hospitals in Thailand have spent the last decade striving to be the biggest and best in the world. They have recruited not only experienced doctors but also embraced foreign management expertise. Singapore, whose global reputation as a medical tourism center has sought to compete with Thailand. Most of the private hospitals in Singapore are participating in the medical tourism program; some of these hospitals have gained international health accreditation from the Joint Commission International (JCI) of the USA. The government has made various efforts to promote healthcare services for the benefit of the medical tourism industry. Malaysia is getting a reputation as one of the preferred locations for medical tourists on account of its excellent and efficient medical staff, as well as advanced healthcare and wellness facilities (Cohen, 2008). Dubai has just built Healthcare City in an attempt to capture the Middle Eastern market and divert it from Asia; the country also plans to include a branch of Harvard Medical School within the Healthcare City, which will make it one of the most prestigious foreign healthcare facilities outside of the west. The main medical treatments offered by Dubai include cochlear implants, diabetes treatments, orthopedics, cardiology, cosmetic surgery and lung treatments Report from medicaltourism.com (2012). Several countries in Central and South America also developed strong reputations for cosmetic and plastic surgery, bariatric procedures and dental care.

The medical tourism issue has been taken into consideration during recent years in Iran. The special position of Iran's geographical location, its history of medical science and existence of expert medical and paramedical workforce, low costs and high quality of its health services, all could increase the importance of medical tourism in economic and medical fields in this country. Considering that the researches on medical tourism issue are sparse in Iran and this subject has a high position of importance, analyzing its current situation could be useful for making decisions about identification and improvement of the areas which are in a high priority, reinforcement of this industry's potentials and finally, attracting more medical tourists. Nowadays, many Asian countries such as Iran, with a high potential for attracting medical tourism have sought to enter the market. Iran offers a wide range of state-of-the-art treatment, through an extensive network of highly-equipped hospitals, around 850 hospitals, and rehabilitation centers at reasonable costs. An analysis of the costs of the various procedures shows that treatment costs in Iran are much lower as compared to the developed countries. Iran is also very cost competitive as compared to its regional competitors, including Jordan, Turkey, UAE, Saudi Arabia, and Bahrain as well as southeast Asian countries such as Thailand, Singapore, Malaysia, Philippines, and India. The unique combination of experience, facilities and natural resources is the key to success of the Iranian health care system. Apart from these, Iran also enjoys a unique range of competent medical staff. Medical specialists and sub-specialists in the country are highly-qualified professionals and are supported by well-trained paramedics and sophisticated medical equipment. The nursing service in Iran is also highly qualified. Further, the Iranian health care system is constantly supported by extensive medical research. Iran has a unique combination of healthy and pleasant climate, wonderful scenery, magnificent historical and cultural

monuments as well as cutting edge technology and sophisticated medical equipment. Before the advent of medical tourism, as we know it today, Iran was known as a destination for treatment of Muslims, attracting thousands of visitors from Persian Gulf countries. Today, medical tourism in Iran is an emerging cluster aiming to provide world-class medical facilities by public-private partnership. While historical data on medical tourism is limited, according to the government, in 2007, there were over 50,000 non-resident patients. Iran has been assembling the various factor inputs necessary for thriving medical tourism cluster. Such factors can be broadly classified as: (1) suitable infrastructure, (2) nice environment, people and culture, and (3) government's key policy. In terms of human resources, Iran has highly competent medical practitioners. The country now has over 850 hospitals nationwide. Hospitals in Iran utilize modern technology. However, the use of modern medical technology, especially high-tech medical equipment, is centered primarily in big cities and private hospitals. Public hospitals do not get involved in medical tourism. In terms of international airports, further investments are needed to improve the quality of infrastructure. Iran has a healthy and pleasant climate, wonderful scenery, and unrivaled historical and cultural monuments. The country is rich in natural resources of spas and hot springs in different cities. This is complemented by internationally recognized warm hospitality of the Iranian people. However, there are some limitations, including: administrative "red tape" in issuing practicing licenses, very limited malpractice insurance and a lack of proficiency in English or other languages in the country. In 2012 Iran launched new plans to expand medical tourism in the region. The Health Tourism Iran hosted 200,000 health tourists in 2012, earning \$1.5 billion, a figure more than double 2011. Last year, more than 4.5 million foreign tourists spent \$9 billion in Iran and created jobs for 2.5 million



people directly or indirectly. Iran's Cultural Heritage, Handicrafts and Tourism Organization (ICHHTO), has conducted studies that suggest the best targets are Iraq, Afghanistan, Persian Gulf states, Central Asian nations and Iranians residing abroad.

The results of analysis of 240 articles related to medical tourism context reveal that since, lot of research about factors (motivations) affecting patient destination choice has been conducted. These researches presented a sporadic classification of motivations. Furthermore, some researches focused on pull and push factor on destination choice behavior. (Grail Research, 2009; Ye et al. 2008; Hong et al. 2007; Ehrbeck, Guevara, & Mango, 2008; Marlowe & Sullivan, 2007; Conell, 2006; Deloitte, 2009; Forgione & Smith, 2007; Heung, Kucukusta, & Song, 2010; Ye et al. 2010; Leng, 2007; Howze, 2007; Garcia, 2005; Burkett, 2007; Kangas, 2007, Horowitz and Rosensweig, 2007; Gray and Poland, 2008; Lunt and Carrera, 2010; Balaban & Marano, 2010; Glinos et al. 2006; Connell, 2006; de Arellano, 2007; Turner, 2007; Hall, 2011; Dunn, 2007; Blesch, 2007; Palvia, 2007; Hudson, 2009; Bookman & Bookman, 2007; Steiner, 2010).

As above aforementioned, at the first, this research attempt to presenting a coherent classification of medical tourist motivations that divided those to three categories named: medical-orientation, tourism-orientation and religious-cultural orientation.

This study developed a theoretical structural model to examine the influence of motivational factor and perceived destination image in the perceived service quality and overall satisfaction of medical tourists who have travelled to a foreign country to obtain a medical treatment. The theory of motivation, perception was combined in this research. This study included customer perceptions based on motivational factor, destination image, quality, value, and satisfaction which occurred after the medical trips. The results show the appropriate measurement model form confirmatory factor

analysis and structural model form structural equation modeling. In addition, causal linked between constructs presents some significant relationships among four constructs

### **Literature review, Conceptual framework and hypothesis**

#### *Medical tourism*

Medical tourism is not a new concept. In ancient times people travelled to various spas, hot springs, and rivers seeking cures and/or rejuvenation. Moreover, Medical tourism burst onto the global scene in the days of classical Greece when Greek pilgrims used to travel from various places throughout the Mediterranean to a small territory in the Saronic Gulf called Epidauria (Connell, 2006). The globalization of health care has given rise to a new form of tourism that is commonly known as health tourism. Within the health tourism arena, medical tourism is among the fastest growing sectors, and many countries are now making legal and practical plans to serve it (Connell, 2008). More recently, people from developing countries have travelled to developed countries seeking more sophisticated medical treatment. However, the contemporary trend is now in the opposite direction as an increasing number of patients from developed countries travel to developing countries to receive medical treatment. The medical tourism industry has been estimated to be a \$60 billion industry, and despite the global economic slowdown, is expected to grow at a rate of up to 35% in coming years. Furthermore, Medical tourism has been developing rapidly in many countries and regions such as India, Thailand, Singapore, and Taiwan. For example, in 2006, there were 410,000 medical tourists visiting Singapore, which generated around USD 900 million. Finally, The market for medical tourism is projected to explode from three quarter million travelers in 2007 to 23 million by 2017, at which time spending on medical tourism is expected to reach US\$79.5 billion per year (Connell, 2011).

Bookman and Bookman (2007) identify three forms of medical tourism: invasive, diagnostic and lifestyle. Invasive treatments involve high-tech procedures performed by a specialist; diagnostic procedures encompass several types of tests such as blood screenings and electrocardiograms; and lifestyle includes wellness or recuperation treatments.

There is four mode model of medical tourism in USA.

**Mode 1: Direct medical tourism.** Consumers who use this mode are familiar with a foreign hospital and make their own arrangements for travel and medical treatment. This is the simplest and earliest mode of medical tourism.

**Mode 2: Medical tourism arranged by medical tourism facilitators (MTFs).** This mode represents consumers who use the services of agencies that specialize in locating suitable foreign hospitals and arranging treatment, transportation, and lodging during recuperation.

**Mode 3: Medical tourism induced by US health plans or by US employers.** As the availability of medical care in foreign hospitals has become more widely recognized and in an effort to contain cost, some employers and insurance companies

have started to provide incentives for covered employees to seek medical care outside the USA. Similarly, some managed-care health plans have included foreign hospitals on their lists of approved providers as a way to reduce costs.

**Mode 4: Medical tourism encouraged by US healthcare providers (DHP).** This is an extension of the common practice of hospitals outsourcing medical services. At the time of writing, there are only a small number of anecdotal instances of this occurring, but as more US hospitals partner with foreign hospitals, as after care is gaining its well-deserved attention in medical tourism, and as consumers become more accustomed to these partnerships, this mode may grow in importance. Some US healthcare providers with international presence are already sharing their management protocols with FHPs (H&HN, 2004).

The idea of traveling around the world for medical treatment has captured the attention of much of the academic press (Balaban and Marano, 2010; Bookman and Bookman, 2007; Connell, 2006). Regarding medical tourism, various definitions has been proposed (see table 1).

Table 1. Definitions Regarding medical tourism

Construct	definition	Source of definition
Medical tourism	As a niche industry within the tourism domain, medical tourism is generally understood to occur when people travel often long distances to overseas countries to obtain medical, dental and surgical care while simultaneously being holidaymakers, in a more conventional sense.	Connell, 2006
Medical tourism	Medical tourism' is commonly used to describe the practice of patients traveling outside of established cross-border care arrangements to access medical services abroad, which are typically paid for out-of-pocket.	Crooks, Kingsbury, Snyder, & Johnston, 2010 Ramirez de Arellano, 2007
Medical tourism	In its broadest conceptualization, medical tourism refers to travel with the express purpose of obtaining health services abroad	Ramirez de Arellano, 2007
Medical tourism	From a destination perspective, medical tourism can be defined as the offshore provision of medical services, in combination with other conventional tourism products, by	Awadzi and Panda, 2005 Percivil and Bridges, 2006

	leveraging a comparative cost advantage.	
<b>Medical tourism</b>	Travel activity that involves a medical procedure or activities that promote the wellbeing of the tourist	Lee & Spisto, 2007
<b>Medical tourism</b>	Medical industry practitioners have defined medical tourism as the act of travelling beyond a home country to receive a health care treatment that is either less expensive or more accessible	Kim, Leong, Heob, Anderson, & Gaitz, 2009
<b>Medical tourism</b>	An economic activity that entails trade in services and represents the splicing of at least two sectors: medicine and tourism	Bookman & Bookman"s ,2007
<b>Medical tourism</b>	Set of activities in which a person travels often long distances or across the border, to avail medical services with direct or indirect engagement in leisure, business or other purposes.	Jagyasi, 2009
<b>Medical tourism</b>	Defined medical tourism as travel for recovery, instead of travel for direct treatment	Hunter-Jones ,2005
<b>Medical tourism</b>	Medical tourism is understood as foreign travel for the purpose of seeking medical treatment with or without the consumption of tourism services	Balaban and Marano, 2010 Connell, 2006
<b>Medical tourism</b>	Described medical tourism as the activity of patients who go abroad to seek healthcare because of some relative disadvantage in their own national healthcare system	Glinos and Baeten ,2006
<b>Medical tourism</b>	Residents seeking medical, dental, and cosmetic surgeries (both elective and non-elective) from healthcare providers outside their home countries.	Gan and Frederick 2011
<b>Medical tourism</b>	Medical tourism refers to travel for the purpose of obtaining medical services in a foreign country where medical technology is advanced as well as affordable, it also encompasses activities such as the intentional marketing of medical services and facilities to foreign patients	Bies & Zacharia, 2007
<b>Medical tourism</b>	Traveling to a destination in another country to receive medical, dental and surgical care because the destination enables better access to care, provides higher quality care or offers the same treatment at a more affordable price	Grail Research, 2009
<b>Medical tourism</b>	Medical tourism as tourism where a person chooses to seek disease prevention or treatment, or to enhance physical and psychological well-being in a country other than their own.	Hong, Lim, and Kim ,2007

Some Terms such as medical travel, medical tourism and health tourism are generally employed to conceptualize the meaning of traveling to another place for health care. For example, a recent study conducted by Ehrbeck et al. (2008) strictly defined medical travelers as people whose primary purpose in traveling is medical treatment in a foreign country. This

definition eliminates the following classes of people: ordinary tourists who suddenly become sick; wellness tourists who travel for massages or acupuncture; expatriates who seek care in their country of residence; and patients who travel in largely contiguous geographical areas to the closest available care. Furthermore, Medical tourism has emerged from the broader notion of

health tourism. Some researchers have considered health and medical tourism as a combined phenomenon but with different emphases. Carrera and Bridges 2006, identify health tourism as the organized travel outside one's local environment for the maintenance, enhancement or restoration of an individual's well-being in mind and body. It encompasses medical tourism which is delimited to organized travel outside one's natural health care jurisdiction for the enhancement or restoration of the individual's health through medical intervention. Past research (Cook, 2010) has defined health tourism as the promotion by a tourist destination of its health facilities and services. While Bookman and Bookman (2007) suggested that in recent usage medical and health tourism both refer to the sale of high-tech medical care to foreigners.

Medical tourism programs are products where excellent medical service is combined with tourism and provided to foreign visitors, earning foreign revenue and developing related industries in addition to those normally developed by travel for leisure (Cormany and Baloglu, 2011). There are numerous definitions of tourists. For example authors as Gonzales, Brenzel and Sancho (2001) for instance, define medical tourists as people traveling to another country specifically to consume health care services, without even making reference to touristic activities. However, it is accepted that tourists are travellers who have travelled and stayed away from their home environment for 24 hours or more, and hence, have often utilized some form of accommodation facility. Those travellers who do not meet this 24 hour criterion are generally referred to as 'visitors'. For travellers that travel overseas for medical purposes, conceptually, they would meet the definition of a tourist. Since medical tourists are travelers whose main motivation for travel is for a specific purpose, medical tourists can be categorized as a group of special interest

tourists, hence participating in a form of special interest tourism (Crooks et.al, 2011). Medical tourism does not refer to care given when one happens to have a health emergency while abroad, as intent is key: the patient must actually intend to go elsewhere for care. Engaging in tourist activities, such as recovering in resorts in destination countries, is a common part of the medical tourism experience (Dalstrom, 2012). Moreover, People who become ill or injured while traveling abroad and require hospital care are not thought to be medical tourists, nor are expatriates accessing care in the countries or regions in which they live.

As mentioned before and For the purpose of this paper For the purpose of this paper medical tourism will be defined using the Medical Tourism Association's definition: Medical Tourism is where people who live in one country travel to another country to receive medical, dental and surgical care while at the same time receiving equal to or greater care than they would have in their own country, and are traveling for medical care because of affordability, better access to care or a higher level of quality of care (Deloitte, 2009). With today's technologies, such as the Internet, mobiles (Smartphones), iPads, the marketplace of medical tourism has become reachable for patients anywhere in the world. King (2009) describes the marketplace as a location where buyers and providers agree on a transaction to occur; medical tourism services can be reached by patients through alternative resources: through their own initiative and research on communication technologies (internet), or with the help of travel agencies which provide facilitators who select the most appropriate medical destinations. However, with today's technology, patients can learn about thousands of medical facilities and opportunities around the world, allowing them to make comparisons and choices based on the most efficient medical

facilities that best suit their specific needs (Edelheit, 2008).

### **Definitions of medical tourism**

Terms such as “medical travel,” “medical tourism,” “health tourism” and “patient mobility” are generally employed to conceptualize the meaning of traveling to another place for healthcare. For example, a recent study conducted by Ehrbeck et al. (2008) strictly defined medical travelers as people whose primary purpose in traveling is medical treatment in a foreign country. Past research (Ehrbeck et al, 2008) has defined health tourism as the promotion by a tourist destination of its health facilities and services. Laws (1996) asserted that health tourism means leisure away from home, with one of the purposes being to promote one’s state of health; similarly, Hall (2003, p. 274) defined health tourism as “a commercial phenomenon of industrial society which involves a person traveling overnight away from the normal home environment for the express benefit of maintaining or improving health.”

Medical tourism is not a new concept. In ancient times people travelled to various spas, hot springs, and rivers seeking cures and/or rejuvenation. More recently, people from developing countries have travelled to developed countries seeking more sophisticated medical treatment. However, the contemporary trend is now in the opposite direction as an increasing number of patients from developed countries travel to developing countries to receive medical treatment. Lee and Spisto (2007) have defined medical tourism in a simple context as a “travel activity that involves a medical procedure or activities that promote the well-being of the tourist”. The most appropriate definition for medical tourism, illustrated by Bookman and Bookman’s (2007, p. 1) study, claims that it is “an economic activity that entails trade in services and represents the splicing of at least two sectors: medicine and tourism”. Jagyasi

(2008) has defined the two terms “tourism” and “medical” individually in order to establish a suitable definition for medical tourism. In this sense, medical tourism can be defined as a “set of activities in which a person travels often long distances or across the border, to avail medical services with direct or indirect engagement in leisure, business or other purposes” (Erbe, 2011). Regarding medical tourism, various definitions have been proposed. Hunter-Jones (2005) defined medical tourism as travel for recovery, instead of travel for direct treatment, while Bookman and Bookman (2007, p. 1) suggested that in recent usage medical and health tourism both refer to “the sale of high-tech medical care to foreigners.” Some scholars have argued that medical tourism is understood as “foreign travel for the purpose of seeking medical treatment” (Gill and Singh, 2011), with or without the consumption of tourism services. Additionally, Hall (2011) suggested that, as of late, medical tourism belongs within the overall context of health tourism. The medical tourism can be defined as “traveling to a destination in another country to receive medical, dental and surgical care because the destination enables better access to care, provides higher quality care or offers the same treatment at a more affordable price”.

### **Medical tourism in Iran**

Iran seems to be an ideal destination for health tourism. Affordability is another key factor bringing patients to Iran. Patients can undergo treatment, recover and enjoy a holiday in Iran for much less than what it would cost them for treatment in other countries. The medical service in Iran is cheap while the healthcare establishments are well equipped and professional. Currently 30,000 foreign patients who are most from the neighbor countries come to Iran to receive medical treatments. Medical Tourism in Iran has been patronized by tourists looking for critical medical treatment as well as by people in need of cosmetic and preventative

care. (<http://dreamofiran.com/dossiers/health-tourism-why-iran/>). Thanks to its geographical position, the conditions in neighboring countries, economically reasonable prices and advanced medical facilities, Iran is gradually becoming a destination for Islamic and regional medical tourists. Hospitals in Iranian cities offer medical and health care services for foreign medical tourists, and for the Iranians who go to large cities from those parts of the country that lack such services. The existence of mineral fountains in many parts of the country, targets one market. Other markets include fertility treatment, stem cell treatment, dialysis, heart surgery, cosmetic surgery, and eye surgery. It also produces unique medicines such as the anti-AIDS drug IMOD, and other high-tech drugs.<sup>30</sup> 000 medical tourists enter Iran annually, and economic surveys show that each medical tourist brings three times as much hard currency to the country than regular tourists. There are also some 200,000 health, wellness and spa tourists.

According to last statistics of statistical center of Iran about 120000 hospital bed and 4551 laboratories, 3042 rehabilitation center, 2293 radiology and imaging centers and 7601 pharmacy are providing health services in Iran. Medical tourism is not new phenomenon in the world as well as in Iran. In the past some people from neighbor countries especially from Arab countries of Persian Gulf came to Iran. In this area in the country, there are no exact statistics about medical tourists came to the country but some resources indicated about 17500 patients came to Iran in 2005. The most popular procedures which are demanded include: advanced treatments of cardiac treatments and surgeries, cosmetic surgeries, productivity treatments, organ transplant (CHN news). The main reasons of coming patient to Iran are: quality of health services and low cost of treatments and drugs in comparison with other countries of the region (Middle East and Middle Asia), access to advanced and new medical

procedures, equipment and qualified professionals and medical staff, similarity of culture and language in some regions of Iran with neighboring counties such as Iraq, Azerbaijan and lack of some medical procedures, equipment, medical professionals and health infrastructures in those countries combined with natural attractions, ancient and historical buildings in famous cities of Iran. Despite of these factors and existence of some legal factors such as the 4th and at present 5th program of economic, social, cultural development of Iran, medical tourism in Iran has not developed yet and some hospitals and medical and health centers individually are working in the area of importing patients from foreign countries and provide health services for them and some patients come to Iran in a traditional way.

Iran, located in the Middle East, is surrounded by Muslim countries such as Iraq, Afghanistan, Pakistan, Turkey, and Azerbaijan, to name a few. The majority of Iran's population is Muslim of the Shi'a sect. Many natural tourist attractions, historical and archeological sites with more than 7000 years of urban settlements, in addition to famous cities that have rich Islamic and pre-Islamic cultural backgrounds such as Isfahan, Shiraz and Yazd are located in Iran (Zende Del, 2001). Moreover, many sacred places for Shi'a Muslims termed "Imam Zadeh" are located throughout Iran (Ministry of Culture and Islamic Guidance, 2003). Some authors investigated medical tourism in Iran and the results of demographical characteristics of their study show that, all respondents were Muslim couples, of which 64.2% were Iraqi, 17.9% Afghan, 7.5% Pakistani and 10.4% were infertile couples from other countries. The majority were Shi'a (94%) and the remainder (6%) Sunni Muslims (three Pakistani and one Iraqi couple). A total of 82.1% of these couples entered Iran by land while the remaining 17.9% traveled by air. Only 6% of these couples encountered problems during their applications for a visa. Of couples, 71.6% rented houses during their treatment period,



16.4% of them stayed at hotels and the remaining 11.9% stayed with their Iranian resident friends or relatives. In addition, most Afghan couples mentioned that they were previously in Iran as social workers (11 out of 12). Finally, 32.8% of males and 49.2% of females had a high school diploma or below, whereas 67.2% of males and 50.8% of females were university graduates.

### ***Motivational factors***

Having been identified in previous research, challenge in the tourism market is that motivation need to be understood by diverse perspectives of features (Gilmartin and White, 2010). Therefore, tourist motivation is an important factor in explaining tourist behavior in relation to destination choice, relating to the needs, goals, and preference of the tourists (Glinos et al, 2010). Extensive previous research has widely accepted that the analysis of motivations is based on the two dimensions of push and pull factors (Goodrich and Goodrich, 1987). Accordingly, "push factors" refer to intangible and intrinsic desires of human beings, including the desire for escape, novelty seeking, adventure seeking, rest and relaxation, health and fitness, and socialization (Gupta, 2008). While "push factors" are the socio-psychological needs that encourage an individual to travel, "pull factors" are considered as the external forces from the attributes that attract a person to a specific destination and establish the actual specific destination choice. From previous study, "pull factors" have been defined in terms of both tangible and intangible features such as natural and historical attractions, physical environment, infrastructure, food, people, sport and recreation facilities (Wilson, 2011). In another explanation, pull motivations have been described as factors influencing when, where and how people travel (Helble, 2011). On the other hand, the main pull factor that lead medical tourists to look for treatment in less developed countries is the low cost treatment. In

addition, affordable air travel and favorable exchange rates are viewed as reasons that pull tourists travel out of their countries for medical treatment (Connell, 2006). In a report from UNESCAP (2007), other important pull factors include the emergence of the state-of-the-art medical facilities in developing countries and the aftercare which is equal in terms of quality. Study of Chen, Prebensen, and Huan (2008) revealed in their study that relaxation, pursuing multiple activities, recreation, and enjoying nature are primary factors of tourists' travel motivation to a wellness destination. Push and pull factors determine not only customer's decision to travel but also the choice of destination. Uysal and Jurowski (1994) concluded in their research that there is a relationship between push and pull factors. The push-pull model is also supported by other researchers (Herrick, 2007). The concept of push and pull factors has been characterized as relating to two separate decisions made at two separate points in time – one focusing on whether to go or not, the other on where to go. In contrast to this opinion, other researchers have supported that push and pull factors should not be viewed as being totally independent of each other but rather as being related to each other. While internal forces push people to travel away, external forces of the destination pull them to choose that particular (Heung and Kucukusta, 2010).

### ***Perceived destination image***

The definition of destination image refers to the impressions that a person has about a place, and this is composed of beliefs, ideas, and prejudices (Higginbotham, 2011). This definition relates to an individual, while other definitions acknowledge that destination images can be shared by a group of people. The impression will help tourists consider whether the destination matches their mental image and recreational demands. The concept of destination image was evolved from an organic image, through an

induced image, to a complex image (Hopkinset al., 2010). These image phases were connected to the functions of promotion, which are informative, persuasive, and remaining. According to Gunn (1972), organic images deal with tourists' impression of a destination without visiting the place, and induced images relate to an image influenced by directed information from the tourism organization. In another research of Echtner and Ritchie (1993), the concept of destination image should be composed of individual attributes' perceptions as well as holistic impressions of the place. Therefore, it is possible to say that destination image involves the images of the individual elements or attributes that contribute to the tourism experience of tourists (Horowitz and Rosensweig, 2008). A number of tourism researchers have studied about the destination image construct and its influence on tourists' behavior, the travel selection process, and travel satisfaction (Horton and Cole, 2011).

### ***Perceived service quality***

In the research field of tourism, the quality of opportunity or performance, and satisfaction and quality of experience are clearly distinguished (Hunter and Oultram, 2010). Quality of performance refers to the attribute of a service which is mainly controlled by service suppliers. Specifically, it is the output of medical service providers at the destination (Reisman, 2010). Therefore, evaluations of the service quality are based on tourists' perceptions of the service performance of the provider. In the past two decades, the theory and practice of service quality has attracted considerable attention from both theoretical and practical knowledge (Parry, 2008). Perceived quality is defined as the consumer' judgment about the superiority or excellence of a product the degree and direction of discrepancy between customers' perceptions and expectations (Inhorn and Patrizio, 2009). A measurement tool called SERVQUAL was developed by Parasuraman et al. (1985) in order

to evaluate service quality (Pollard, 2010). A 22-item instrument represents five dimensions by which consumers evaluate service quality: tangibility, reliability, responsiveness, assurance, and empathy (Sengupta, 2011). Reliability is considered as the most important dimension which concerns whether the outcome of service delivery was as promised, while the other four dimensions refer to the process of service delivery (Jones, 2011). However, it was very difficult to translate SERVQUAL to measure health care services due to the generic service quality dimensions. Hence, Jun, Peterson and Zsidisin (1998) narrowly focused on dimensions that are applicable to health care. The results of this study pointed out eleven dimensions: tangibles, reliability, responsiveness, competence, courtesy, communication, access, caring, patient outcomes, understanding patient, and collaboration (Thompson, 2011).

### ***Overall Satisfaction***

Previous literature has suggested that customer overall satisfaction with a hospitality experience is the sum of satisfaction with the individual elements or attributes of all the products and services that create the experience (Kangas, 2007). Therefore, when experiencing hospitality experiences, customers tend to form a set of independent impressions on each and compare those with the expectations of the same attributes. In a highly competitive market like medical tourism, sustainable competitive advantage is very important and dependent on the ability to deliver high service quality that will satisfy customers (Kangas, 2011). Customer satisfaction, in general, is a comparison between the expectation of value (before the purchase) and the perceived value (after the purchase). Baker and Crompton (2000) identified that satisfaction in tourism refers to the emotional state of tourists after exposure to the opportunity or experience. Since medical tourists are travelers who combine medical treatment and tourism together, Saiprasert

(2011) suggested looking at the concept of “patient satisfaction” of health care industry. Linder-Pelz (1982) proposed five determinants of satisfaction in health care services: occurrences, value, expectations, interpersonal comparisons, and entitlement. In another study of Sitzia and Wood (1997), they classified four components of patient satisfaction in terms of accessibility, interpersonal aspects of care, technical aspects of care, and patient education/information. The result suggested that two strongest predictors of satisfaction were older age and better self-perceived health status at admission. The study of Thi, Briancon, Empereur, and Guillemin (2002) investigated seven satisfaction dimensions of in-patients receiving medical and surgical care from hospital. The seven dimensions are: admission, nursing and daily care, medical care, information, hospital environment and ancillary staff, overall quality of care and services, and recommendations (Veerasoontorn et al, 2011).

### ***Hypothesis development***

Applying the push and pull factors deriving from the motivational attributes, the perceived quality of medical treatment experience can be measured (Knudsen, 2011). According to a research of Crooks et al (2010), push and pull factors incorporate service quality attributes of the medical service providers at the destination, along with the destination perception, process of travel and medical tourism experience as a whole. Therefore, the following hypothesis is proposed:

*H1: Motivational factors have significant effect on the perceived quality of the medical treatment at the destination.*

Previous researchers have studied the influence of destination image on tourists’ behavior, the destination selection process, and travel satisfaction (Laugesen and Vargas-Bustamante, 2010). In the tourism and marketing literature, destination image is positively related to the

service quality at a sport event (Lee et al, 2012). This view is also supported by Chen and Tsai (2007) and Lee et al. (2005). These researchers stated that tourists having a favorable destination image would perceive their onsite experiences (perceive service quality, perceived value) positively, which then lead to higher satisfaction levels. In another research of Kotler, Bowen, and Makens (1996), they proposed the following sequence: image, quality, satisfaction. In this case, destination image could affect the way customers perceive quality. Moreover, previous literature also pointed out that destination image positively influences perceived quality and satisfaction because it creates expectations that individuals form before the visit (Lefebvre, 2008).

Another research (Lunt and Carrera., 2010) has indicated the influence of tourism image on consumer behavior. This study examined the relationship between destination image and perceived quality and customers’ satisfaction. The results supported the view that image of destination is a direct antecedent of perceived quality, and satisfaction. The following hypothesis is proposed based on the discussion of previous literature of destination image and perceived service quality:

*H2. Medical tourists’ perceived destination image positively influences their perceived service quality of medical treatment.*

Perceived service quality has been considered to be one of the critical antecedents of both satisfaction (Martin, 2009) and perceived value (Mazzaschi, 2011). The theoretical justification for the connection between perceived quality, perceived value and satisfaction is taken from a coping framework of Bagozzi (1992), in which he suggested that initial service evaluations lead to emotional reactions, thus in turn, drive consumer behavior. Previous literature, which has adapted Bagozzi’s framework to the service context, suggest that higher performance-

oriented service quality and value appraisals precede satisfaction (Moghimehfar and Nasr-Esfahani, 2011). Bolton and Drew (1999) developed a model of customers' assessments of service quality and satisfaction by using customers of telephone service. The study concluded that perceived service quality has an important direct effect on service value assessment, hence, directly affects the overall satisfaction of customers. In another research of McDougall and Levesque (2000), they investigated the relationship between service quality, perceived value and customer satisfaction in different areas: restaurant, dentist, and auto service. The result revealed that service quality was the most important drivers of customer satisfaction. A major conclusion of this study was that both perceived value and perceived service quality attributes should be incorporated into customer satisfaction models to explain a more complete picture of drivers of satisfaction. Baker and Crompton (2000) focused their study on quality, satisfaction and behavioral intentions of tourists. In this research, quality was conceptualized as the attributes of a service which were controlled by suppliers, while satisfaction referred to tourists' emotional state after experiencing tourism activities. The hypothesis of perceived quality would have strong effect on satisfaction and behavioral intentions was confirmed with the results. Petrick (2004) examined the relationships between satisfaction, perceived value, and quality in predicting cruise passengers' behavioral intentions. The three constructs have been examined from three

different perspectives to assess which one best explained customers' intentions to repurchase. The results showed that quality was the best predictor of behavioral intentions with cruise passengers. However, in this study, it was found out that there was a correlation between perceived quality and satisfaction. Lee, Graefe, and Burns (2004) conducted a research on service quality and satisfaction on forest visitors. The study concluded that service quality is an antecedent of satisfaction and satisfaction had a moderate effect on forest visitors' behavioral intention. In a study on health care customer satisfaction (NaRanong and NaRanong, 2011), researchers proposed a relationship among service quality, value, patient satisfaction and behavioral intention. 537 responses were collected from South Korea medical consumers to analyze the model. Between two observed constructs (service quality and value), service quality appeared to be a more important determinant of patient satisfaction than value. Results also revealed that both service quality and value had significant effect on repurchase intention while value was influenced by perceived quality.

Based on the previous literature discussed above, the following hypothesis is proposed:

*H3. Medical tourists' perceived quality positively influences their overall satisfaction of medical treatment at the destination.*

The conceptual model concluded all the above hypotheses is presented in figure 1 as below:

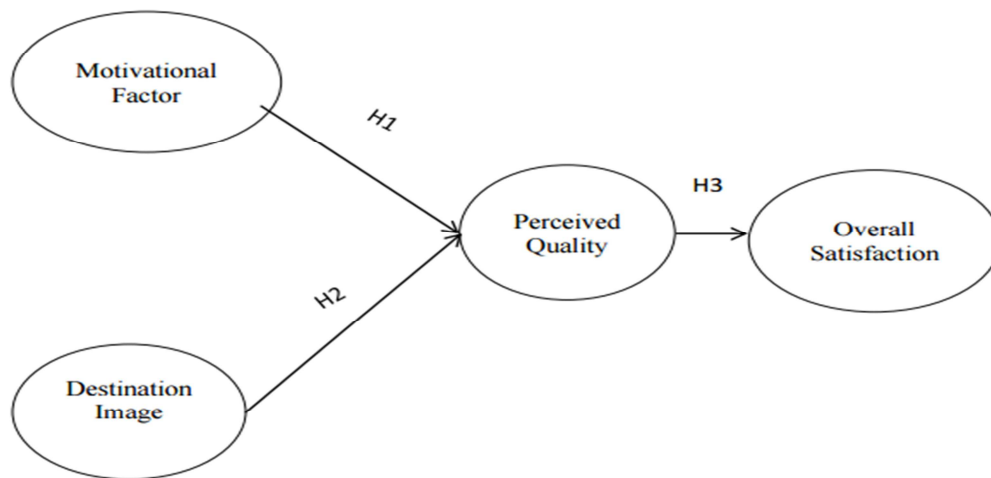
**Figure 1.** Conceptual model

## METHODOLOGY

This is a quantitative study and survey method is used to collect data. The instrument of this study is developed based on the review of previous literature on motivational factors, perceived destination image, perceived service quality, perceived value and overall satisfaction. Survey questionnaire is used as main data gathering instrument to test the reliability and validity of the conceptual model and research hypotheses. In instrument development stage, the related studies are searched for building construct measurement. The questionnaire consisted of five sections. The first section of the questionnaire collected information regarding to behaviors of medical tourists. The questions in this section include reason and type of medical treatment seeking, sources of information, frequency of travelling for medical tourism, medical insurance coverage, the destination traveled to for medical treatment, alternative choice of destination if considered, travel arrangement and approximately time to spend on medical tourism. Respondents were required to answer the entire question that was

appropriate to their circumstance. The second section gathered information related to motivation factors and destination image. In this section, respondents were asked to rate their agreement on the different attributes of push and pull factors, as well as the perceived destination image. The 5-point Likert-scale ranging from “strongly disagree” to “strongly agree” was used in this section.

The third section explored respondents’ perception of perceived quality of medical treatment after their medical tourism experience. The questions included medical and nonmedical related attributes such as hospital reputation and accreditation, physicians experience, medical services, medical equipment and amenities, hospital, appointment and reservation system, protection and liability. Participants were asked to rate attributes on a 5-point Likert scale with the anchors of 1 = “Strongly disagree” and 5 = “Strongly agree”.

The following table lists the categorized attributes of the perceived quality of medical treatment.



**Table 2.** List of Motivational Factors and Perceived Destination Image Attributes

<b>Motivational Factors and Perceived Destination Image Attributes</b>	<b>Construct</b>
Waiting time for medical service	Push factor
Total cost of medical treatment	Push factor
Type of medical treatment that is not allowed	Push factor
Type of medical treatment not covered by medical insurance	Push factor
Privacy and confidentiality	Push factor
Opportunity for person who has limited or no medical insurance	Pull factor
Ease of visa procedures	Pull factor
Recognized hospital/medical facility reputation	Pull factor
High standard level of medical staff	Pull factor
Recognized, positive reputation of physicians	Pull factor
Western experienced/trained physicians	Destination image
Ease of medical treatment arrangements	Destination image
A great place for relaxation after medical treatment	Destination image
Political stability	Destination image
Variety of existing tourist attractions for recuperating patients	Destination image
Opportunity to combine medical service with a vacation	Destination image
Tourism safety from crime and/or terrorist attack	Destination image
Ease of travel arrangements	Destination image
Ease of lodging arrangements	Destination image
Ease of transportation	Destination image
Friendliness and helpfulness of the local people	Destination image
No language barriers in travelling to your destination	Destination image
Ease of accessibility when travelling	Destination image

**Table 3.** List of Perceived Service Quality Attributes

<b>Perceived Quality of medical treatment Attributes</b>	<b>Construct</b>
Process for setting up the medical appointment was simple and easy	Process
Medical records and information was easily assembled and transmitted	Process
Short waiting time for medical examination	Process
Physicians adequately explained condition, examination results, and medical process	People
Physicians allowed to ask questions, enough to clarify everything	People
Hospital/medical facility had a strong concern for patient safety	Protection
Hospital/medical facility valued and respected patients' privacy and confidentiality	Protection
Payment procedure was quick and simple	Price
Provided convenient transportation arrangements	Additional service
Language interpretation service arrangement was provided	Additional service
Effective coordination of arrangements between patient involved, hospital, third-party insurance companies, and/or other involved businesses	Additional service
Destination was a good place to relax after treatment	Additional service
Destination was a good place for a vacation	Additional service
Costs associated with medical treatment	Price



In the fourth section of the questionnaire, respondents were asked to measure attributes relating to overall satisfaction of medical treatment in the form of 5-point Likertscale. In the last section, the demographic information of the respondents was collected with the

questions regarding to gender, age, marital status, occupation, annual income. This information was collected to fully understand the respondents' background, and to make comparisons among sample groups for further analysis.

**Table 4.** Final Construct Measurement Scales

Construct	Measurement
<b>MOTIVATIONAL FACTORS (MF)</b>	
MF1	Shorter waiting time
MF2	Less expensive medical treatment
MF3	Type of medical treatment that is not allowed
MF4	Type of medical treatment not covered by medical insurance in your country
MF5	Ease of visa procedures
MF6	Political stability
<b>DESTINATION IMAGE (DI)</b>	
DI1	A great place for relaxation after medical treatment
DI2	Positive reputation as a tourist destination
DI3	Variety of existing tourist attractions for recuperating patients
DI4	Opportunity to combine medical service with a vacation
DI5	Preference of privacy and confidentiality
<b>PERCEIVED QUALITY (PQ)</b>	
PQ1	Short waiting time for medical examination from the physician
PQ2	The physicians adequately explained my condition, examination results, and medical process
PQ3	The medical facility valued and respected patients' privacy, confidentiality, and disclosure
PQ4	Provided assistance with financial arrangements, such as: advanced estimates for fees, deposits, and payments
PQ5	The payment procedure was quick and simple
PQ6	The physicians allowed me to ask many questions, enough to clarify everything
<b>OVERALL SATISFACTION (OS)</b>	
OS1	Overall, I was satisfied with my medical treatment during my trip abroad
OS2	Overall, I was satisfied with the hospital/medical facilities services during my trip abroad
OS3	Overall, I was satisfied with the hospitality services (lodging, transportation, dining, tourism services) during my trip abroad
OS4	Overall, I was satisfied with my medical trip abroad
OS5	Overall, I was satisfied with the destination I traveled to for medical treatment

#### Data collection

Online survey had been distributed to the participants via Qualtrics, an online survey research platform. This third-party data collection service looked for potential respondents that meet the criteria of the research: individuals must have been primarily living in their country at the time of their medical trip, and they must have travelled to a foreign country to obtain medical procedures. At the end of the data collection period, out of 500 individuals that Qualtrics screened, there were

400 qualified for this study. However, there were only 260 completed responses that met all the required criteria. The sample included individuals who travelled abroad for medical treatment.

#### Data analysis techniques

After data collection was completed, the Statistical Package for Social Sciences (SPSS) and SPSS AMOS 22.0 will be used to analyze and interpret the result. Descriptive statistics were initially conducted to provide an overview of the

respondents. Secondly, the reliability check (Cronbach Alpha) was applied to the data of the main survey in order to conduct a preliminary test of the validity and reliability of the scales to measure the construct. Thirdly, CFA (Confirmatory Factor Analysis) is conducted. Finally, SEM (Structural Equation Modeling) is applied to test the relations between latent, observed variables, and hypotheses (Hoyle, 1995).

#### Result of descriptive statistics

This survey was fairly distributed to both gender. Out of 260 respondents, 55.8% were male (145) and 44.2% were female (115). The sample of this study comprised of six different age groups, which the majority were respondents from 26 to 35 years old (42.3%), followed by 22.3% of respondents between ages 36-45. The smallest number of this sample belongs to people in the age group of 56-65 (6.5%). Most of the respondents from this study were married (70%), 21.9% were single, and only 8.1% were divorced. Professional/technical was the most common occupational group in this sample with the highest percentage of 30.8%, followed by self-employed (18.8%), Government/military group had the lowest percentage of 1.9%.

#### Descriptive statistics of factors

The next two sections are going to give descriptive statistics of four factors of the proposed model to understand the relationship between independent variables and dependent variables.

#### *Independent variables*

The descriptive show customers' perception about factors that influence on perceived quality of medical treatment and the overall satisfaction of the medical tourists. Between two factors, perceived destination image has a higher average mean value of 4.02 ranging from 3.88 to

4.13. The result shows that the motivational factor and destination image are relatively important to medical tourists when coming to choose a place for medical treatment. Between two independent variables (motivational factor and destination image), the average of destination image (4.02) is slightly higher than that of motivational factor (3.87); therefore, it is possible to say that customers might consider the factor of destination image more than motivation factor. Moreover, MF2 (less expensive price) has the highest mean (4.20) among all the variables, which means that customers perceived this factor as the most important one. In contrast, it is surprising that MF6 (political stability) received the lowest mean value among 260 medical tourists.

#### *Dependent variables*

With the average mean value of 4.19, the result indicates a relatively important perception of medical tourists about the service quality at the destination. Respondents most agreed with factor PQ3 "value and respect patients' privacy, confidentiality, and disclosure", illustrated by the high mean (4.30) among the group. Participants were really satisfied with the medical procedures they received after the medical trip abroad. This can be explained by the extremely high mean value of all five factors (all higher than 4.0). Additionally, among five factors, OS1 "satisfied with medical treatment during the trip abroad" received the highest value. Therefore, it is possible to say that medical treatment is considered as the main purpose of the trip abroad and the most important factor when evaluating their satisfaction.

#### Confirmatory factor analysis (CFA)

the final result after running CFA is shown in the figure below:

Figure 2. Confirmatory Factor Analysis Result

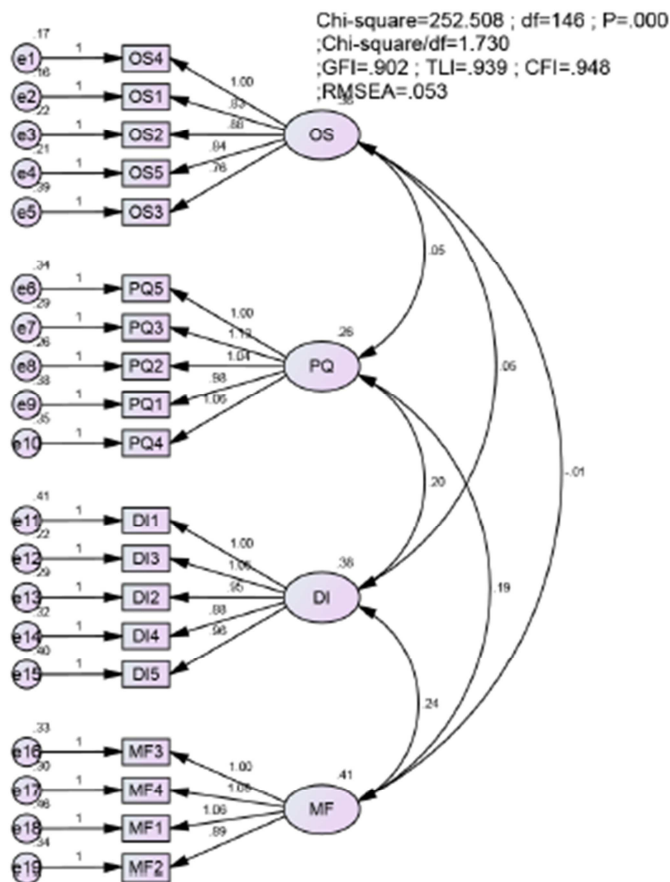

Table 5. Correlation

	Estimate
PQ <--> OS	.151
PQ <--> DI	<b>.641</b>
PQ <--> MF	.571
OS <--> DI	.137
OS <--> MF	-.033
DI <--> MF	.607

In order to create a model fit for the study, the CFA result value need to be compared with the threshold value mentioned above in Chapter 3.

Base on the CFA result, all value is satisfied with the threshold.

**Table 6.** CFA result vs. threshold

Threshold	CFA Result
CFI>=0.9	CFI = 0.948
CMIN/df<=3	CMIN/df = 1.730
RMSEA<=0.08	RMSEA = 0.053
Standardize Regression Weights > 0.5	<b>All factors are greater than 0.5</b>

Final model

In the process of analyzing SEM, the first step was to assess the model fit using various

measures-of-fit indices. The final SEM model was presented in the figure below.

**Figure 3.** Structural Equation Modeling Result

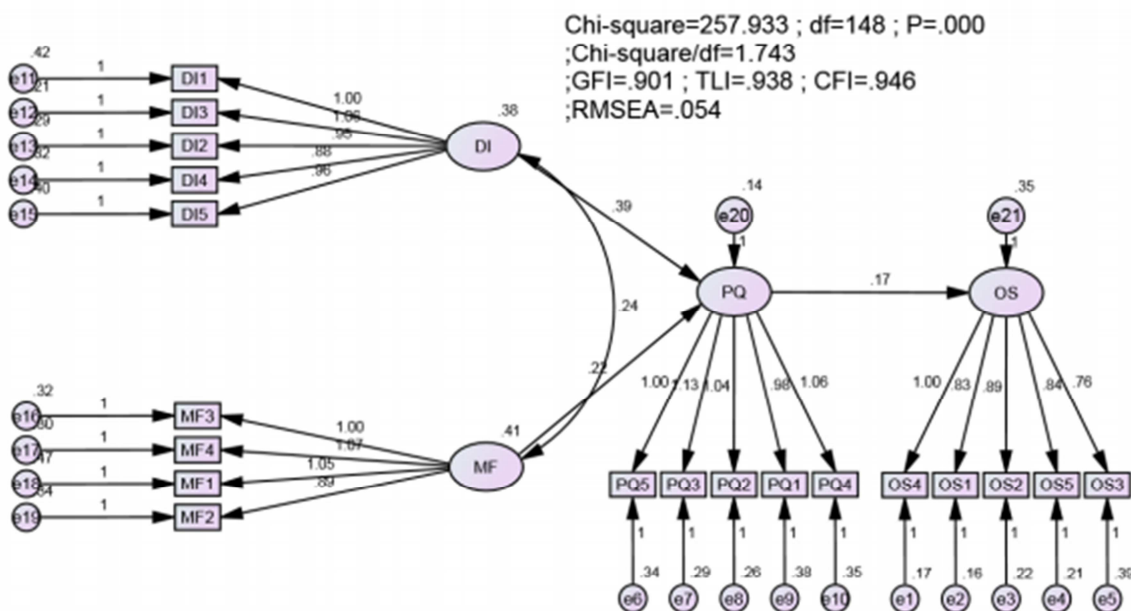

**Table 7.** Fit Statistics for Final Model

<i>Model Fit Statistics</i>					
Chi-Sq = 258	df = 148	NFI = 0.883	CFI = 0.946	GFI = 0.901	RMSEA = 0.054

According to the result from table 7, this model had a relatively good fit.

The regression weights table indicates that Destination Image, Motivational Factor have the p value smaller than 0.05. Therefore, we can

conclude that these two factors have positive significantly impact on the Perceived Quality. Other than that, with a p value smaller than .05, Perceived Quality is proportionally positive influence factor towards Overall Satisfaction. It can also be concluded that with the estimate

value of .373, Destination Image has the strongest influence on Perceived Quality, followed by the effect of Motivational Factor on Perceived Quality and Perceived Quality on Overall Satisfaction, illustrated by the regression weight estimated value of .224, .170.

**Table 8.** Regression Weights

	Estimate	S.E.	C.R.	P	Label
PQ ← DI	.373	.073	5.105	***	
PQ ← MF	.224	.071	3.163	.002	
OS ← PQ	.170	.085	1.994	.046	
PQ5 ← PQ	1.000				
PQ3 ← PQ	1.126	.117	9.628	***	
PQ2 ← PQ	1.038	.109	9.526	***	
PQ1 ← PQ	.979	.114	8.596	***	
PQ4 ← PQ	1.062	.117	9.077	***	
OS4 ← OS	1.000				
OS1 ← OS	.833	.063	13.182	***	
OS2 ← OS	.887	.071	12.491	***	
OS5 ← OS	.838	.068	12.260	***	
OS3 ← OS	.764	.081	9.460	***	
DI3 ← DI	1.000				
DI1 ← DI	.947	.083	11.365	***	
DI2 ← DI	.902	.074	12.232	***	
DI4 ← DI	.835	.073	11.445	***	
DI5 ← DI	.908	.081	11.221	***	
MF3 ← MF	1.000				
MF2 ← MF	.889	.086	10.373	***	
MF4 ← MF	1.072	.093	11.474	***	
MF1 ← MF	1.051	.101	10.413	***	

The effect of the dependent variables on the independent variables in this research can also be explained by standardized regression weights. Standardized regression weights present the standardized estimate value of the impact of Destination Image and Motivational Factor on Perceived Quality and Overall Satisfaction. The standardized values are all positive, therefore, there were positive impact of Destination Image and Motivational Factor on Perceived Value, and positive impact of

Perceived Value on Overall Satisfaction. Once again, it can be confirmed that Destination Image has the strongest impact on Perceived Quality, illustrated by the highest standardized value of .473.

Hypotheses results:

According to the results concluded from SEM, the proposed Hypotheses are answered as following:



**Table 9.** Hypotheses result

		Path Coef.	Standard Error	t-value	p-value	Results
<b>H1</b>	Motivational Factors -> Perceived Quality	0.224	0.071	3.163	0.002	Supported
<b>H2</b>	Destination Image -> Perceived Quality	0.373	0.073	5.105	<0.001	Supported
<b>H3</b>	Perceived Quality -> Overall Satisfaction	0.170	0.085	1.994	0.046	Supported

Model fit:  $\chi^2= 258$ ,  $df= 148$ ,  $NFI= .883$ ,  $GFI= .901$ ,  $TLI= .938$ ,  $CFI= .946$ ,  $RMSEA= .054$

### Discussion and conclusion

Hypothesis 1 proposed a relationship between motivational factors and customers' perceived quality of medical treatment at the destination. The standardized path coefficient of the relationship between motivation factors and perceived quality was ( $p<.005$ ) which indicated that motivation was a significant predictor of medical tourists' perceived quality. The results demonstrated that if customers were more likely to be motivated to go to the chosen destination, they had a positive perception towards the quality of medical service providers at the destination. Hypothesis 2 suggested a positive influence of perceived destination image to perceived quality of the medical treatment at the destination. This hypothesized relationship was supported by the equivalent estimate of 0.373 ( $p<0.001$ ) showing that individuals with higher perception towards the image of the chosen destination tend to perceive higher quality of medical procedures at the medical facilities. In addition, compared to motivational factors, the perceived destination image has more significant impact on perceived quality with higher value of standardized path coefficient. This means that between two variables, destination image is a stronger predictor of medical tourists' perceived quality. Hypothesis 3 indicated that perceived quality

positively influences medical tourists' overall satisfaction at the medical destination. This proposed relationship was supported by the equivalent estimate of .170 ( $p<.005$ ) showing that perceived quality significantly influenced customer's overall satisfaction. The result supported the notion that medical tourists with positive perception of service quality of medical facilities and chosen destination were more likely to be satisfied. There is no significant interaction effect between motivational factor and perceived destination image, only direct effects of independent variables on dependent variables were taken into consideration. The findings of this study reveals that shorter waiting time has the most significant impact on the motivation factors with medical tourists when choosing the destination. This result was also supported from previous literature (Connell, 2007; Ormond, 2011; Hall, 2011). Other than that, cost was also found as the main driver of medical tourists' motivational factor with a relatively high estimated value (0.748). Within the destination image factor, all five observed variables present a significant impact with high factor loadings, wherein the third item "variety of existing tourist attractions for recuperating patients" appears to be the most important. All the results were presented in the SEM model. While there is no significant correlation found



between two independent variables, direct effects were pointed out between observed and latent variables in this study. Previous literature showed a strong relationship between motivational factor and perceived quality (Yoon & Uysal, 2005, Crooks et al., 2002). Tourists that are highly motivated to travel to the chosen destination might perceive the service quality higher than who are not. In terms of the relationship between destination image and perceived quality of medical tourists, the result indicated that destination image had a positively significant influence on perceived quality. Similarly, Bigne et al. (2001) concluded that destination image is a direct antecedent of

perceived service quality. The finding of this study also supported the previous literature indicated that destination image creates a positive influence on perceived quality and satisfaction, because it forms expectations that individuals have before the trips (Phelps, 1986, Bigne et al, 2001). Previous literature indicated a strong impact of perceived service quality on overall customer satisfaction. The result of this study also supported that positive influence. When medical tourists perceived the high quality of medical staff, they are likely to be more satisfied with not only the provided service but also with the chosen destination itself.

## REFERENCES

- Ackerman, S. (2010). Plastic paradise: transforming bodies and selves in Costa Rica's cosmetic surgery tourism industry. *Medical Anthropology*, 29, 403e423.
- Al-Hinai, S., Al-Busaidi, A., & Al-Busaidi, I. (2011). Medical tourism abroad. A new challenge to Oman's health system e Al Dakhilya region experience. *Sultan Qabus University Medical Journal*, 11, 477e484.
- Alleman, B., Luger, T., Reisinger, H., Martin, R., Horowitz, M., & Cram, P. (2011). Medical tourism services available to residents of the United States. *Journal of General Internal Medicine*, 26, 492e497.
- Alsharif, M., Labonté, R., & Zuxun, L. (2010). Patients beyond borders: a study of medical tourists in four countries. *Global Social Policy*, 10, 315e335.
- Anon. (2009). MTA releases first patient surveys on medical tourism. *Medical Tourism Magazine*, 10, 34e36.
- Augé, M. (1995). *Non-places*. London: Verso.
- Bagheri, A. (2010). Global health regulations should distinguish between medical tourism and transplant tourism. *Global Social Policy*, 10, 295e297.
- Basu, P. (2004). My own island home. The Orkney homecoming. *Journal of Material Culture*, 9, 27e42.
- Bookman, M., & Bookman, K. (2007). *Medical tourism in developing countries*. Basingstoke: Palgrave Macmillan.
- Brown, H. (2008). Do Mexican immigrants substitute health care in Mexico for health insurance in the United States? The role of distance. *Social Science and Medicine*, 67, 2036e2042.
- Buzinde, C., & Yarnal, C. (2012). Therapeutic landscapes and postcolonial theory: a theoretical approach to medical tourism. *Social Science and Medicine*, 74, 783e787.
- Carrera, P., & Bridges, J. (2006). Globalization and healthcare: understanding health and medical tourism. *Expert Review of Pharmacoeconomics and Outcomes Research*, 6, 447e454.
- Chee, H. (2010). Medical tourism and the state in Malaysia and Singapore. *Global Social Policy*, 10, 336e357.

- Cohen, E. (2008). Medical tourism in Thailand. In E. Cohen (Ed.), *Explorations in Thai tourism* (pp. 225e255). Bingley: Emerald.
- Connell, J. (2006). Medical tourism: sea, sun, sand and .. surgery. *TourismManagement*, 27, 1093e1100.
- Connell, J. (2008). Tummy tucks and the Taj Mahal? Medical tourism and the globalization of health care. In A. Woodside, & D. Martin (Eds.), *Tourism management* (pp. 232e244). Wallingford: CABI.
- Connell, J. (2011b). A new inequality? Privatisation, urban bias, migration and medical tourism. *Asia Pacific Viewpoint*, 52, 260e271.
- Cook, P. (2010). Constructions and experiences of authenticity in medical tourism: the performances of places, spaces, practices, objects and bodies. *Tourist Studies*, 10, 135e153.
- Crooks, V., Turner, L., Snyder, J., Johnston, R., & Kingsbury, P. (2011). Promoting medical tourism to India: messages, images, and the marketing of international patient travel. *Social Science and Medicine*, 72, 726e732.
- Dalstrom, M. (2012). Winter Texans and the re-creation of the American medical experience in Mexico. *Medical Anthropology*, 31, 162e177.
- Deloitte. (2009). *Medical tourism: Update and implications*. Washington D.C.: Deloitte Center for Health Solutions.
- Edelheit, J. (2008). Defining medical tourism or not? *Medical Tourism Magazine*, 5, 9e10.
- Ehrbeck, T., Guevara, C., & Mango, P. (2008). Mapping the market for medical tourism. *McKinsey Quarterly*, May, 1e11.
- Erbe, B. (2011). 'Maternity tourism' in San Gabriel. *Korea Times*, 2 April.
- Gilmartin, M., & White, A. (2010). Interrogating medical tourism: Ireland, abortion and mobility rights. *Signs*, 36, 275e280.
- Glinos, I., Baeten, R., Helble, M., & Maarse, H. (2010). A typology of cross-border patient mobility. *Health and Place*, 16, 1145e1155.
- Goodrich, J., & Goodrich, G. (1987). Health-care tourism e an exploratory study. *Tourism Management*, 8, 217e222.
- Gupta, A. (2008). Medical tourism in India: winners and losers. *Indian Journal of Medical Ethics*, 1, 4e5.
- Helble, M. (2011). The movement of patients across borders: challenges and opportunities for public health. *Bulletin of the World Health Organisation*, 89, 68e72.
- Heung, V., Kucukusta, D., & Song, H. (2010). A conceptual model of medical tourism: implications for future research. *Journal of Travel and Tourism Marketing*, 27, 236e251.
- Higginbotham, G. (2011). Assisted-suicide tourism: is it tourism? *Tourismos: An International Multidisciplinary Journal of Tourism*, 6, 177e185.
- Hopkins, L., Labonté, R., Runnels, V., & Packer, C. (2010). Medical tourism today: what is the state of existing knowledge? *Journal of Public Health Policy*, 31, 185e198.
- Horowitz, M., & Rosensweig, J. (2008). Medical tourism vs. traditional international medical travel: a tale of two models. *International Medical Travel Journal*, 3, 30e33.
- Horton, S., & Cole, S. (2011). Medical returns: seeking health care in Mexico. *Social Science and Medicine*, 72, 1846e1852.
- Hunter, D., & Oultram, S. (2010). The ethical and policy implications of rogue medical tourism. *Global Social Policy*, 10, 297e299.
- Inhorn, M., & Patrizio, P. (2009). Rethinking "reproductive tourism" as "reproductive exile". *Fertility and Sterility*, 29, 904e906.
- Jenner, E. (2008). Unsettled borders of care: medical tourism as a new dimension in

- America's health care crisis. *Research in the Sociology of Health Care*, 26, 235e249.
- Jones, M. (2011). Clinics of oblivion: makeover culture and cosmetic surgery tourism, portal. *Journal of Multidisciplinary International Studies*, 8(2), 1e17, (online).
  - Kangas, B. (2007). Hope from abroad in the international medical travel of Yemeni patients. *Anthropology and Medicine*, 14, 293e305.
  - Kangas, B. (2011). Complicating common ideas about medical tourism: gender, class and globality in Yemenis' international medical travel. *Signs*, 36, 327e332.
  - Knudsen, B. (2011). Thanatourism: witnessing difficult pasts. *Tourist Studies*, 11, 55e72.
  - Laugesen, M., & Vargas-Bustamante, A. (2010). A patient mobility framework that travels: European and United-States Mexican comparisons. *Health Policy*, 97, 225e231.
  - Lee, M., Han, H., & Lockyer, T. (2012). Medical tourism e attracting Japanese tourists for medical tourism experience. *Journal of Travel and Tourism Marketing*, 29, 69e86.
  - Lefebvre, B. (2008). The Indian corporate hospitals: touching middle class lives. In C. Jaffelot, & P. van de Veer (Eds.), *Patterns of middle class consumption in India and China* (pp. 88e109). New Delhi: Sage.
  - Lunt, N., & Carrera, P. (2010). Medical tourism: assessing the evidence on treatment abroad. *Maturitas*, 66, 27e32.
  - Moghimehfar, F., & Nasr-Esfahani, M. (2011). Decisive factors in medical tourism destinations choice: a case study of Isfahan, Iran and fertility treatments. *Tourism Management*, 32, 1431e1434.
  - NaRanong, A., & NaRanong, V. (2011). The effects of medical tourism: Thailand's experience. *Bulletin of the World Health Organisation*, 89, 336e344.
  - Parry, B. (2008). Entangled exchange: reconceptualising the characterisation and practice of bodily commodification. *Geoforum*, 39, 1133e1144.
  - Pollard, K. (2010). Medical tourism statistics: Comparing apples with apples. <http://treatmentabroad.blogspot.com/2010/03/medical-tourism-statistics-comparing.html>.
  - Reisman, D. (2010). *Health tourism. Social welfare through international trade*. Cheltenham: Edward Elgar.
  - Sengupta, A. (2011). Medical tourism: reverse subsidy for the elite. *Signs*, 36, 312e319.
  - Smith, P., & Forgione, D. (2007). Global outsourcing of healthcare: a medical tourism model. *Journal of Information Technology Case and Application Research*, 9(3), 19e30.
  - Thompson, C. (2011). Medical migrations afterword: science as a vacation? *Body and Society*, 17, 205e213.
  - Veerasoontorn, R., Beise-Zee, & Sivayathorn, A. (2011). Service quality as a key driver of medical tourism: the case of Bumrungrad International Hospital in Thailand. *International Journal of Leisure and Tourism Marketing*, 2, 140e158.
  - Wilson, A. (2011). Foreign bodies and national scales: medical tourism in Thailand. *Body and Society*, 17, 121e137.

# ETHICAL ISSUES AND SELLING: PERCEPTIONS OF MEN AND WOMEN

Eileen Wall Mullen, Suzanne N. Cory and Guillermo Martinez

## **Abstract:**

*More college women are majoring in marketing in recent years, resulting in a feminization of the sales occupation. The question then arises as to whether the increased number of women interested in a sales career will change the ethics climate therein. Business students were asked make decisions that could be required of individuals in the sales occupation, based on six different scenarios and results were analyzed based on gender. While no significant statistical differences were found in the decisions made by gender, some differences were found in the moral reasoning provided by the males and females in the study.*

**Key words:** sales profession, gender differences in ethics; moral reasoning, ethical issues and selling

**Category:** Research Paper

## **Introduction**

According to Newton-Small (2016, p. 5), the sociological meaning of “critical mass” refers to “the [tipping] point at which a minority begins to change the tone and policies of the institution it has begun to integrate.” In her recent thought-provoking book, she talks about a “critical mass” of women, and a tipping point which she estimates as just more than 20%, as an essential ingredient for their acceptance in the workplace. She also remarks on the changes regarding women in the workforce that have occurred in the recent past, noting, among other issues, that 20 years ago women often could not even wear pants to work, that just 10 years ago it was not unusual for females serving as U.S. senators to be mistaken for wives or staffers in the senate

chamber, and that there was no restroom for them off the senate floor until 1993.

The number of women in graduate school began to exceed the number of men in 1984 and in 2012, according to the Council of Graduate Schools, women earned 63 percent of all master’s degree, and 54 percent of all doctorates. The Committee for Economic Development reported that women earned one third of all MBAs awarded in that same year. Further, according to Carnevale, Strohl and Melton (2011), business is the most popular college bachelor’s degree, earned by 25% of all graduates. About 12% of business school graduates choose marketing or marketing research as a major, and within this group, 51% of graduates are female. Sales career opportunities are expanding rapidly and the number of women in sales and related occupations continues to grow (Donoho, Heinze, and Kondo, 2012). This is strong evidence of the continued increase in the number of women entering the field of business and establishing a career in sales.

**Eileen Wall Mullen**, Ph.D., Greehey School of Business, St. Mary’s University, San Antonio, Texas 78228.

Telephone: 210-431-2028, Fax: 210-431-2115, email ewall@stmarytx.edu

**Suzanne N. Cory**, Ph.D., St. Mary’s University, San Antonio, Texas

**Guillermo. Martinez**, J.D., St. Mary’s University, San Antonio, Texas

As this trend persists, interest continues in the question of whether ethical decision making differences exist between the genders. With approximately equal numbers of men and women entering the workforce with degrees in marketing, will the moral landscape in sales change? Are moral reasoning and judgements different between men and women? Will the genders bring different ethical values to the workplace? Others have attempted to answer this question, with differing results.

These questions are of interest because the sales profession tends to be more vulnerable for unethical conduct than other areas of business. Dawson (1992) notes that individuals in sales often perform their duties without direct supervision, confront conflicts resulting from interfaces to which other occupations are not subject, and are faced with making daily decisions that have ethical dimensions. With the increase of women in this occupation, the question then arises as to whether women will affect the ethical climate of the sales arena.

The purpose of this paper is to report the results of a study replicating previous research by Dawson (1995) using the same six scenarios that he developed. However, the focus of the current paper is on business students rather than on marketing professionals currently in the workforce. These students are on the threshold of their careers and will be entering a dramatically different business arena than what existed in 1995. This research questions the processes of ethical decision making, in addition to determining any differences in those decisions by gender.

### **Prior Research**

Gender differences in preferences have been heavily researched. Croson and Gneezy (2009) provided an extensive literature review on gender inclinations and identified significant differences in the areas of risk preferences, social (other-regarding) preferences, and competitive preferences. When comparing

gender differences in these areas, they reported that women are more risk-averse, women's social preferences are more situationally specific, and women are more averse to competition. This is strong evidence of gender differences in these specific areas.

Prior research has addressed gender differences in ethical decision making from a variety of aspects. Gilligan's 1982 seminal and sometimes controversial book is widely recognized as the foundation for many research projects. Gilligan suggested that, due in part to gender socialization, men and women solve moral dilemmas differently. Hence, men and women will make different moral decisions in the workplace. Men tend to succeed through competition, and hence are more willing to act unethically, but women succeed through nurturing and are therefore more sensitive to ethical issues (Kohlberg, 1984; Roxas and Stoneback, 2004).

Focusing on sales, Dabholkar and Kellaris (1992) developed the Personal Selling Ethics Scale, which has been used to test for differences between the genders when evaluating the degree to which respondents feel a situation is or is not ethical. Use of the scale by Donoho, Herche and Swenson (2003) found that females evaluated sales ethics dilemmas as less ethical than did their male counterparts. Using an updated version of the scale, Donoho, Heinze and Kondo (2012) again found that women evaluated sales ethics scenarios as less ethical than did males in their study. Further, they implied that emphasis on moral idealism when teaching sales ethics may help to alleviate this difference.

Other research continues to indicate that women tend to be more ethical than men (Dobson and White, 1995; Beu, Buckley and Harvey, 2003), but others (Sikula and Costa, 1994), disagree about any difference in ethics between the genders. In their review of the ethics literature covering the time span 1996 to 2003, O'Fallon and Butterfield (2005)

determined that 23 of the 49 articles published during those years showed few gender differences in ethical evaluations. However, among the studies where differences were found, women evaluated ethical situations more stringently than did men. Men have been found to be less ethically sensitive to a large variety of issues (Smith and Oakley, 1997, Vermeir and Van Kenhove, 2008). Finally, Franke, Crown and Spake, (1997) suggested that women are more likely to view unethical behavior unfavorably in the business environment.

These differences have been researched in students for several years (Dawson, 1992; Lane, 1995; Loe and Weeks, 2000; Silver and Valentine, 2000; Ryan, David and Reynolds, 2004; Keith, Perreault, Chin and Keith, 2009; Donoho, Heinze, and Kondon, 2012) as well as men and women in the workforce (Kidwell, Stevens and Bethke 1987; Tansey, Brown, Hyman and Dawson, 1994; Dawson, 1995; Dawson, 1997; Hunt 1997; Weeks, Moore, McKinney, and Longenecker, 1999; Smith and Rogers, 2000; Ingram, LaForge and Schwepker, 2007; Singhapakdi and Vitell, 2007) Possible explanations for gender differences include emotional understanding, moderated competitiveness, biological foundations or genetics, generalized trait differences between the genders and socialization (Grimshaw, 1992; Pool, 1994; Hunt, 1997; Weeks, Moore, McKenney and Longenecker, 1999). However, few studies have attempted to capture the actual decision making processes of males and females when deciding on appropriate actions. Although Malinowski and Berger (1996) speculated about how undergraduates feel, think and act when faced with an ethical dilemma, their study did not capture that information. Rather, the method employed in their study was the presentation of hypothetical marketing moral dilemmas to students and asking them to use a ten-point interval scale to react cognitively, affectively, and behaviorally to them. The actual thought process, moral

reasoning and justification for the action(s) chosen were not captured. Notably, Dawson's 1995 study illuminated the processes and moral reasoning used by males and females when making decisions about ethical dilemmas. The current study is modeled from his work, using his vignettes, but having students as respondents.

Some have argued against using students as research subjects, questioning whether the results are generalizable. However, Lucas (2003) indicated that samples drawn using college students are appropriate when the research concerns basic psychological processes, or gathering data that are independent of sample characteristics. Further, as future business leaders they represent a population of interest and information gathered using this sample may be informative for use both inside and outside the classroom (Abdolmohammadi, Gabhart and Reeves, 1997; Ahmed, Chung and Eichenseher, 2003; Borkowski and Ugras, 1998). Finally, they may be used to replicate prior studies. The current study encompasses these criteria.

The sample consisted of undergraduate business students in a small, private, faith-based university located in south Texas. Seventy scenario packets were distributed, with each packet containing six scenarios. The scenarios asked respondents to choose the decision they would make: "Yes, I would\_\_\_\_", or "No, I would not\_\_\_\_". Subjects were then asked to explain their decision. Each scenario was printed on a separate page, with adequate space available for their narrative explanation. Sixty-five completed packets were returned for a response rate of 93%. Responses were tabulated and the Chi-square statistic was calculated for each of the six scenarios to determine statistical significance of any gender difference in responses. If the student responded both "yes" and "no," the response was coded as "unsure." Two of the researchers read each response in order to ensure agreement in interpretation of the comments made by the subjects.



**Scenario 1: “Break Promise?”**

This scenario puts the respondents in the role of a manager of a toy store during the holidays. “Would you break a promise to previous customers and sell a scarce toy to a woman who claims her child is very ill?” Our results showed both men and women were more likely to keep the promise to the original customers and not sell the toy to the woman with the sick child. The reasons given for their choices followed similar themes, with both stating that; it wasn’t right to break a promise, or the woman’s story couldn’t be verified. Both also mentioned that they’d try to work out a solution with the original 12 customers, while only females mentioned finding a different toy for the sick child. However, only the females (five of those who indicated they would not sell to the distressed mother) stated that it was the mother’s own fault for waiting so late in the holiday season to procure Peter Panda and only

females indicated they would “feel bad” if they did not sell to the mother. Both genders mentioned selling to the mother would be the “right thing to do.”

Scenario 1: You are the manager of a local toy store. The hottest Christmas toy of the year is the new “Peter Panda” stuffed animal. The toy is in great demand and almost impossible to find. You have received your one and only shipment of 12, and they are all promised to people who previously stopped in to place a deposit and reserve one. A woman comes by the store and pleads with you, saying that her six-year-old daughter is in the hospital, very ill and that “Peter Panda” is the one toy she has her heart set on. Would you sell her one, knowing that you will then have to break your promise and refund the deposit to one of the other customers? (There is no way you will be able to get an extra toy in time.)

**Figure 1: “Break Promise?”**

Decision:	Would Sell	Would Not Sell	Unsure
Males	34%	62%	3%
Females	22%	78%	0%

Chi Square = 2.673; p=.263

Male Voices

“Yes, but I’d verify the story first.”

“Yes, because the child might not survive. I’d work it out with the other 12 customers.”

“I have no way of verifying that this woman is telling the truth.”

“Although I feel bad for the child, I have already made a promise to twelve customers to hold the toy for them. If I go back on my word, it could potentially harm my business.”

“I don’t like to break my promises. For the good image of my business, I have to stick to what I agreed to with my clients.”

“Promises are more important. I would contact the list of customers, tell them about the situation, and if anyone agreed to give up their toy, I would sell it to her.”

Female Voices

“Yes, but I would call the hospital to verify she is telling the truth.”

“Her daughter’s situation is more important than my promises.”

“By accepting deposits from the original twelve customers, I promised they would be guaranteed a toy, and it would be dishonest to go back on my word to them.”

“I have no idea if she is telling the truth.”

“Unfortunately, I cannot break a promise to someone who already paid and made it clear they wanted the toy. The mom could also just be making up the story about her daughter being in the hospital.”

"Although the situation is heartbreaking, I do not know my other 12 customers' situations. I have a duty to my customers to keep my word of promising them the toy. I would refer the woman to another local toy store and try my hardest to find her one in stock. I have already received deposits for my shipment which is in turn a contract."

"I have already reserved the toy for other people, but I would see if there's a way I could have her settle for another toy."

### Scenario 2: "Take Plan?"

The second scenario presented respondents with an issue of personal honesty. As shown in Figure 2, there was no significant difference in the responses of males and females, with over 60% saying they would not take the plan. There was some similarity in the narratives, such as: blaming the Dynamark executive who left the plan ("it was his own fault"); or stating that taking the plan would be stealing or unethical; or fear of being seen/caught. There were also some narrative differences: only males said they wouldn't take the plan because they suspected the situation may be a trap; or that it just wasn't

playing fair in business. On the other hand, more females than males (eight out of ten females versus five out of ten males) who replied "yes," indicated it would be "advantageous" to their company or to their own careers to take the plan. More females than males said they would take the plan only to return it to its rightful owner. Additionally, only females indicated they would "feel bad" if they took the plan and used it. In addition, females exhibited empathy, putting themselves in the shoes of the forgetful executive.

Scenario 2: You are a salesperson for Omega Computers. One of your major competitors is Dynamark Computers. You are attending a trade association meeting, and you notice that the marketing director of Dynamark is carrying a stack of copies of Dynamark's marketing plan for the next year. After this person has left the room, you notice that one of the copies has inadvertently been left on the table. It would be easy for you to pick up this copy without being observed, which would give you important intelligence about your competitor's plans. Would you take the copy?

Figure 2: "Take Plan?"

Decision:	Would Take	Would Not Take	Unsure
Males	34%	62%	3%
Females	28%	72%	0%

Chi Square = 1.721; p = .423

#### Male Voices

"They should have been more careful about leaving it."

"It would give me/my company an advantage."

"It was not my fault it was left there in the first place. My career could potentially be advanced by being able to best my competitors with any of the information found on that business plan. Whoever was put in charge of those copies should have been more aware of what they

were doing. They will be held accountable for the mistake that I will capitalize on."

"I wouldn't copy it; I'd make a better plan."

"It is not ethical and would not show integrity. I would return it."

"I consider it cheating. My competitor was just unlucky and I shouldn't take advantage of such a situation."

"If anyone sees me and we are accused of copying, I could lose my job."

"I want my product to be unique. There is always going to be competition, so there is no point in cheating"

"It is not the right thing to do, and beating a competitor in that fashion is a poor way to win, and certainly not a way I would want to win in business."

#### Female Voices

"It would help my company. Omega Computers might reward me for the information I provide."

"It'll provide me and my team with valuable information about our competitor"

"It is unethical. Yes, they are my competitor, but I wouldn't steal their marketing plan to see what they will be doing. That shows weakness."

"I don't know if it may be a trap. Either way, I wouldn't take it because that is not how I am. I would instead get the copy and give it back to my competitor."

"The consequences of me getting caught would be too severe. I wouldn't risk my job or the credibility of the company that I am representing."

"I wouldn't want someone to steal my ideas if I had been so careless as to drop one of my plans."

"I would want to get ahead on my own merit."

#### **Scenario 3: "Tell about the Product?"**

In this scenario respondents are placed in the role of a medical supplies salesperson who must decide whether to share information about a superior competitor's product with a surgeon who is about to perform an operation. As

indicated in figure 3, while both men and women were most likely to tell the surgeon about the superior product, women were slightly more likely than men to disclose the information. Justifications most often provided by both genders were that they would want to do what is best for the athlete. Both genders who responded "no" indicated that they had a responsibility to their employer, didn't want to give their competitor an advantage or that they were "trying to sell a product" themselves. A few responses from both genders indicated they felt it was the surgeon's responsibility to determine what prosthetic would be best for the patient and felt no obligation to provide information about a competitor's product.

Scenario 3: You are a salesperson in the medical supplies field, selling to physicians and hospitals. Your product line includes prosthetic devices such as artificial limb replacements. As a product expert, sometimes you are asked to be present during surgical operations to provide advice and guidance in the proper fitting of your products. A surgeon you have worked with in the past has asked for your advice concerning knee surgery he will be performing on a professional athlete. You have an appropriate prosthetic product that would be suitable, but you also happen to know that a competitor has just developed a new state-of-the-art device that you believe would perform much better for this particular condition. Would you tell the surgeon about the competitor's product?

**Figure 3:** "Tell about the Product?"

Decision:	Would Tell	Would Not Tell	Unsure
Males	69%	28%	3%
Females	81%	19%	0%

Chi Square = 1.989; p=.370

#### Male Voices

"It is the morally correct thing to do."

"I would inform the surgeon about it because I know if I was the athlete I would want the best for me."

"It will help me gain the surgeon's trust."

"It is for the well-being of a patient. Although I will not be making profit, I would still feel good knowing that the player's knee would be in a better state despite not using my product."

"My product is already suitable. I might briefly mention the competitor's product, but encourage him to use my product. It would not be right for me to promote my competitor."

"It is the competitor's job to tell the surgeon his product is better. My job is to maximize profit, not level the playing field."

#### Female Voices

"I ultimately want what is best for the athlete."

"It is someone's health at risk and I would like that person to get the best treatment."

"Even though you want to sell your own product, you have to consider what is best for the patient. You need to help the patient more than yourself."

"At the end of the day, the goal is to improve lives. Informing the physician of the alternative would lead to a reputation as an ethical company and earn credibility."

"The surgeon would know I could be trusted."

"I would relate to my own needs. If I was that professional athlete I would want the best I could get. This competition would also help me develop a new product that would ultimately be better than my competitors."

"No, because it is the surgeon's responsibility to be informed of other products and if I know that my product would work for the athlete, then there is no problem if he gets my product."

"That would result in the loss of sales for my company."

#### **Scenario 4: "Consult Psychologist?"**

When a salesperson is dealing with an important potential client who is manic depressive, is it

ethical to consult a psychologist for coaching on how to influence him? This scenario focuses on relational as well as the possible issues of betraying a confidence or tampering with a person's mental health. As indicated in Figure 4, only slightly more females than males would consult the psychologist. In the narrative responses, while both men and women said that consulting the psychologist would only help them relate better to Scott, males stated there was nothing wrong with it, as long as the client remained anonymous. Additionally, both genders indicated the need to "help Scott" and nearly half of each gender (ten of the males and 12 of the females who responded "yes") indicated that consulting the psychologist would help them make the sale. Justification for answering "no," on the part of both genders, indicated that doing so was "not right" or "unfair."

Scenario 4: You sell corporate financial products, such as pension plans and group health insurance. You are currently negotiating with Paul Scott, treasurer of a Fortune 500 firm, for a sale that could be in the millions of dollars. You feel you are in a strong position to make the sale, but two competitors are also negotiating with Scott, and it could go either way. You have become friendly with Scott, and over lunch one day he confided in you that he has recently been under treatment for manic depression. It so happens that in your office there is a staff psychologist who does employee counseling. The thought has occurred to you that such a trained professional might be able to coach you on how to act with and relate to a personality such as Scott's so as to persuade and influence him most effectively. Would you consult the psychologist?

**Figure 4:** "Consult Psychologist?"

Decision:	Would Consult	Would Not Consult	Unsure
Males	72%	24%	3%
Females	74%	23%	3%

Chi Square = .064: p=.969

### Male Voices

"I am not doing anything unethical. I am using my resources in order to relate to and understand Scott."

"Yes, because it would give me a competitive edge."

"I would want to know how to approach my client in a way that does not contribute to his depression. If I approach him a certain way, I may be able to get him out of his depressed state and make it easier to make a sale."

"I would want to help Scott as a friend. Once Scott recognizes our camaraderie on a level deeper than business, I have a better chance of landing the sale."

"I am using resources directly under my purview, in a way that does not represent a conflict of interest with the counselor since Scott is not one of his patients. I would not be taking advantage of Scott, simply learning how to deal with him with the most tact and professionalism."

"That is manipulation of someone with depression, and that is the wrong way to get what you want. The fact that he confided in you should be reason enough not to see the psychologist."

"I don't think it's necessary because if he was friendly enough to tell me his problem, then that means I am doing something right and he trusts me. Therefore, I would simply rely on my skills."

### Female Voices

"It will ultimately help my business and knock out the competition. I feel that meeting with the psychologist about Scott will just teach me how to act around him and it's not hurting anyone."

"It would help me understand Scott's thought process on how to persuade him, but I could also recommend the psychologist to him in order to help him with his depression."

"It could help me relate to Scott more; therefore giving me an advantage for the sale."

"It gives me a competitive edge. Understanding clients is very important for all businesses. However, I would use my information from the

psychologist to communicate more efficiently over the deal."

"That would mean I would have the upper hand in the ongoing deal, and potentially win it. You need to do everything legally possible to give your company an upper hand."

"It would be unethical to use the knowledge of his mental illness in the company's favor."

"Manic depression is difficult to deal with and intentionally consulting the psychologist in order to manipulate Scott could result in doing harm to his health."

### **Scenario 5: "Provide Gift?"**

This is a classic sales situation. The buyer of an important account wants an expensive gift. Providing such a gift would violate company policy, while not providing it could lose the account. Figure 5 shows that neither gender would provide the gift. Narrative responses showed similar themes between males and females. Both genders cited providing the golf clubs would be a violation of company policy or rules, however a slightly higher percentage of males (six of 20) than females (eight of 30) exhibited more fear than females of getting caught and/or losing their job. The few who responded "yes," cited career advancement as the primary reason and two males as well as two females wrote that they would buy the golf clubs themselves and give them to the customer. One enterprising female indicated she would provide one club per month to the customer, thus avoiding violation of company policy by keeping each gift under the \$50 limit. One male suggested that in addition to providing the gift being beneficial to his career, he could get money from the customer to "ensure confidentiality" and thus could actually make a few extra dollars on the side. Only the females (two) expressed concern about future expectations on the part of the customer should they provide the gift. Both responses from the females alluded to the possibility of the

customer wanting more in the future, thus making this only the beginning of having to supply expensive gifts at personal risk.

Scenario 5: As a sales representative for Northstar Sporting Goods, you have been assigned an important account, the Downeast store chain. Downeast's purchasing manager has quickly make it clear that he expects special favors; he has hinted broadly that a new set of

golf clubs would please him. You can sneak such a set—worth about \$800—out of the warehouse without anyone knowing, but it would violate your company's policy that gifts to customers should not exceed \$50 in value. If you ask your sales manager, the "gift" will no doubt be forbidden. At the same time, if you lose this account, no matter what the reason, it is bound to hurt your career. Would you provide the gift?

**Figure 5:** "Provide Gift?"

Decision:	Would Provide	Would Not Provide	Unsure
Males	24%	69%	6%
Females	17%	83%	0%

Chi Square = 3.362; p=.186

### Male Voices

"This type of circumstance helps you to develop links with people which will eventually help you. However, I wouldn't steal them, I would pay for them."

"It is bound to hurt my career if I don't. The policy can be overlooked since it is not a huge deal."

"It is breaking company policy. I cannot simply go around looking for favors just to keep my job. A line has to be drawn somewhere. I am not going to put myself in hot water with my manager to keep an account. I would rather start again somewhere else."

"That is business ethics. I am loyal to the company that hired me. I prefer to get laid off for not giving the \$800 gift than cheating my company. And I am sure if I talked to my manager he would understand the situation."

"The potential consequences outweigh the potential benefits, and it is stealing. I might buy them myself and give them to him on a personal basis, but I would never steal from the company."

"If I were to somehow get caught further down the line, I would lose my job anyway. Plus, the special favors he wants would only get more expensive and frequent."

### Female Voices

"I would buy them myself and then invite him to play golf and give him the clubs. If his opinion really matters, I'd try my best to give him what he wants."

"My career is on the line. I would want to please my customers rather than not have a job at all. It's a risk I am willing to take because my job is on the line."

"It would be stealing and my company forbids gifts over \$50. Stealing would hurt my career more than losing an account due to proper ethics."

"I didn't buy the golf clubs out of my own pocket but stole them. If I'm caught, I will no doubt go to jail. There will always be other opportunities to further my career but I won't do anything to put my career in danger."

"It goes against company policy. At the end of the day, my career is worth more than one account."

"It will ultimately hurt my career."

"If the sales manager finds out I gave away the golf clubs, I could lose my job. I will tell the sales manager about the situation, and seek his advice on how to handle this customer."



**Scenario 6: “Hire Handicapped?”**

When hiring for a sales position, the best-qualified candidate is someone who has suffered severe disfigurement as a result of a self-less act of rescuing an auto accident victim from fire. You are afraid customers may be turned off by his appearance. Additionally, the candidate lost both hands during the incident. To hire or not to hire is the question in scenario 6. As shown in figure 6, fewer men (12 of 27) than women (22 of 36) would hire the handicapped candidate. In the narrative responses for those who responded “no,” both genders cited the fact they believed the handicapped candidate could not do the job, and both genders (three of the 14 females and five of the 15 males) considered looking for an alternative such as putting the candidate in another position. The males who indicated “yes,” they would hire the individual most often simply indicated that he was the best qualified. In addition to indicating that this

candidate was the best qualified, only the females indicated that it was the “right thing” to do, a willingness to help others or it would “not be fair” otherwise.

Scenario 6: As the sales manager for an office equipment firm, you are considering three candidates for an open sales position. The best qualified in terms of background and experience happens to be an individual who recently suffered severe facial disfigurement and the loss of both hands in rescuing a motorist from a burning car. You are concerned that potential customers might be made extremely uncomfortable by this candidate’s appearance. You have a possible legal “out” under equal opportunity laws insofar as the handicap could be construed as interfering with the person’s ability to perform all aspects of the job, such as carrying bulky demonstration units into prospects’ offices. Would you offer the job to the handicapped person?

**Figure 6: “Hire Handicapped?”**

Decision:	Would Hire	Would Not Hire	Unsure
Males	45%	52%	3%
Females	61%	39%	0%

Chi Square = 1.953; p=.377

**Male Voices**

“No matter what the handicap is, if he is the best candidate for the position, he should be the one to receive the job. Also, as a bonus, hiring him may improve the businesses’ public image.”

“He is the best qualified; simple as that.”

“Appearance is the least of my worries. If the customer gets uncomfortable, their nerves can be put to rest if this person’s background is true. Yeah, sure there may be an elephant in the room with the disfigurement, but who cares, if the employee can do his job effectively then I want him working for me, regardless of appearance.”

“He does not have hands. Personally it does not matter to me what a person looks like. If he or she can get the job done and has a good background and experience, then I would hire

him/her. However, this handicapped person does not have hands, which could slow my business down and cause delays.”

“As a result of his accident he is no longer the most qualified candidate. A salesperson must be able to connect to the customer and his disfigurement would prove to be difficult. I do not believe sales is a job suited for him anymore.”

“I believe, because of his accident, he wouldn’t be able to complete his job. However, if he is such a great candidate, I would offer him a job in another position.”

**Female Voices**

“He has the background and experience to succeed in this position and will be a good fit for

the job. I will also avoid any possible legal trouble and gain a good employee.”

“I would want to help others and give him a chance. However, I would observe him and if he is not passionate about his job I see him being a bad example to other employees, I would fire him.”

“Skills should be what is considered, not looks or disability. It might make some people uncomfortable but business should be done in an ethical manner, so I would definitely hire him.”

“He would make customers uncomfortable, and in business, customers have the ultimate power. If they are uncomfortable, it could result in a loss of sales. However, I would give him another job.”

“He is not able to do all the job requires. He may be qualified, but he’s not what I am looking for.”

“I don’t believe he is still the best person for the job after his accident.”

“In sales, one must be presentable to a customer in order to be convincing. The customer’s focus has to be the product, not the salesperson’s face.”

In addition to finding no statistical difference between the genders’ responses for any of the six scenarios, analysis of their reasoning for reaching decisions determined that they differed only occasionally. For example, in the first scenario, only females blamed the mother for waiting until the last minute to acquire the toy for her ill child, and only females indicated they would feel bad if they did not sell to the mother. Females indicating that they would “feel bad” also occurred slightly more frequently than for males in the scenario dealing with whether to take the marketing plan. In the last scenario, only females referred to hiring the handicapped as the right thing to do, indicated a willingness to help others, or stated that not hiring him would be unfair. However, most of the reasoning for the decisions reached in each scenario did not differ substantially between the genders.

These results are dissimilar from those of Dawson’s 1995 study. He found significant differences between responses by gender in four of the six scenarios. Some of the difference may be related to the use of different samples. Dawson’s sample consisted of members of a professional organization of marketing and sales managers, and students majoring in business were used in the current study. Thus, his sample was comprised of an older group of experienced individuals with marketing experience.

Another possible explanation for the difference may be in the adaptation of business to women’s increased participation in the professional business environment. Since the 1970s, women’s participation rate in the workforce has steadily grown to peak at 60% in 1999. In 2013 women’s participation rate stood at 57.% (Bureau of Labor Statistics, 2014). Not only are more women in the workforce, they are now more equally represented in business professions. According to the U.S. Bureau of Labor Statistics, women fill over 51% of management and related occupations, and 43% of marketing and sales manager positions. This increased participation may have allowed women to have a greater impact on ethics policies and practices.

In addition, women are participating in the workforce at higher levels of management. Forbes, for example, reported a record 24 female CEOs in the Fortune 500 in 2014, compared to only one female Fortune 500 CEO in 1998 (Fairchild, 2014). This trend not only gives women a direct impact on ethics policies; it also provides an indirect impact as these female leaders act as role models for young women in business. As a result, it may be that we have reached Newton-Small’s (2016) ‘tipping point,’ where women have achieved the ‘critical mass’ necessary to impact ethics policy and practice in business. This is a notable difference from what Newton-Small cites as the biggest complaint from women in the Navy ranks. She indicates that these women feel there are not enough

female role models up the chain of command to which they can aspire. This is apparently not

the case in marketing. This seems to be an area that is ripe for future research.

## REFERENCES

- Abdolmohammadi, M.J., Gabhart, D.R.L., and Reeves, M.F. (1997). Ethical cognition of business students individually and in groups, *Journal of Business Ethics*, 16, 1717-1725.
- Ahmed, M.M., Chung, K.Y. and Eichenseher, J.W. (2003). Business students' perception of ethics and moral judgment: A cross-cultural study, *Journal of Business Ethics*, 43 (1), 89-102.
- Beu, D., Buckley, M, and Harvey, M. (2003). Ethical decision-making: A multidimensional construct, *Business Ethics: A European Review*, 12 (1), 88-106.
- Borokowski, S.C. and Ugras, Y.J. (1998). Business students and ethics: A meta-analysis, *Journal of Business Ethics*, 17 (11), 1117-1127.
- Bureau of Labor Statistics, (2014). *Women in the labor force: A databook*. Retrieved from <http://www.bls.gov/opub/reports/cps/women-in-the-labor-force-a-databook-2014.pdf>. Viewed March 2, 2016.
- Carnevale, A. P., Strohl, J. and Melton, M. (2011). What's it worth? *Georgetown University Center on Education and the Workforce*.
- Crosen, R. and Gneezy, U. (2009). Gender differences in preferences, *Journal of Economic Preferences*, 47 (2), 448-472.
- Dabholkar, P. and Kellaris, J. (1992). Toward understanding marketing students' ethical judgment of controversial personal selling practices, *Journal of Business Research*, 24 (4), 313-329.
- Dawson, L.M. (1992). Will feminization change the ethics of the sales profession? *Journal of Personal Selling & Sales Management*, 12 (1), 21-32.
- Dawson, L.M. (1995). Women and men, morality and Ethics, *Business Horizons*, 38 (4), 61-68.
- Dawson, L. (1997). Ethical differences between men and women in the sales profession, *Journal of Business Ethics*, 16 (11), 1143-1152.
- Dobson, J. and White, J. (1995). Toward the feminine firm: An extension to Thomas White, *Business Ethics Quarterly*, 5 (3), 463-478.
- Donoho, C., Heinze, T, and Kondo, C. (2012). Gender differences in personal selling ethics evaluations: Do they exist and what does their existence mean for teaching sales ethics? *Journal of Marketing Education*, 34 (1), 55-66.
- Donoho, C., Herche, J. and Swenson, M. (2003). A cross cultural study of the effects of achievement and relationship values on student evaluations of personal selling ethical dilemma, *Marketing Education Review*, 13 (3), 53-63.
- Fairchild, C. (2014). Number of Fortune 500 Women CEOs Reaches Historic High, *Forbes*, June 3, 2014 Retrieved from <http://fortune.com/2014/06/03/number-of-fortune-500-women-ceos-reaches-historic-high/>. Viewed March 2, 2016.
- Franke, G., Crown, D., and Spake, D. (1997). Gender differences in ethical perceptions of business practices: A social role theory perspective, *Journal of Applied Psychology*, 82 (6), 920-934.
- Gilligan, C. (1982). *In a different voice: Psychological theory and women's development*, Cambridge, MA: Harvard University Press.
- Grimshaw, J. (1992). The idea of a female ethic, *Philosophy of East and West*, 42 (2), 221-239.

- Hunt, A. (1997). Are women more ethical than men? *Baylor Business Review*, 15 (1), 7.
- Ingram, T., LaForge, R. and Schwepker, C. (2007). Salesperson ethical decision making: The impact of sales leadership and sales management control strategy, *Journal of Personal Selling and Sales Management*, 27 (4), 301-315.
- Keith, N.K., Perreault, H.R., Chin, M. and Keith, M. (2009). The effect of gender on the importance of business ethics and managerial decisions: A student perspective, *The Delta Pi Epsilon Journal*, 51 (3), (3), 125-136.
- Kidwell, J., Stevens, R.E., and Bethke, A. (1987). Differences in ethical perceptions between male and female managers: Myth or reality? *Journal of Business Ethics*, 6 (6), 489-493.
- Kohlberg, L., (1984). Moral stages and moralization: The cognitive development approach. In essays on moral development: Vol. 2. *The psychology of moral development: The nature and validity of moral stages* (pp. 170-205). San Francisco, CA: Harper and Row.
- Lane, J.C., (1995). Ethics of business students: Some marketing perspectives, *Journal of Business Ethics*, 14 (7), 571-580.
- Loe, T.W., and Weeks, W.A. (2000). An experimental investigation of efforts to improve sales students' moral reasoning, *Journal of Personal Selling and Sales Management*, 20 (4), 243-251.
- Lucas, J.W. (2003). Theory testing, generalization, and the problem of external validity, *Sociological Theory*, 21 (3), 236-253.
- Malinowski, C. and Berger, K.A. (1996). Undergraduate student attitudes about hypothetical marketing dilemmas, *Journal of Business Ethics*, 15 (5), 525-535.
- Newton-Small, J. (2016), *Broad influence: How women are changing the way America works*, New York: Time Books.
- O'Fallon, M. and Butterfield, K. (2005). A review of the empirical ethical decision-making literature: 1996-2003, *Journal of Business Ethics*, 59 (4), 375-413.
- Pool, R. (1994). *Eve's rib: Searching for the biological roots of sex differences*, New York, NY: Crown.
- Roxas, M. and Stoneback, J. (2004). The importance of gender across cultures in ethical decision-making, *Journal of Business Ethics*, 50 (2), 149-165.
- Ryan, M.K., David, B., and Reynolds, K.J. (2004). Who cares? The effect of gender and context on the self and moral reasoning, *Psychology of Women Quarterly*, 28 (3), 246-255.
- Sikula, A. and Costa, A., (1994). Are women more ethical than men? *Journal of Business Ethics*, 13 (11), 859-871.
- Silver, L.S. and Valentine, S.R. (2000). College students' perceptions of moral intensity in sales situations, *Journal of Education for Business*, 75 (6), 309-314.
- Singhapakdi, A. and Vitell, S. (2007). Institutionalization of ethics and its consequences: A survey of marketing professionals, *Journal of the Academy of Management Science*, 35 (2), 284-294.
- Smith, S., and Oakley, E. (1997). Gender-related differences in ethical and social values of business students' implication for management, *Journal of Business Ethics*, 16, 37-45.
- Smith, A. and Rogers, V. (2000). Ethics-related responses to specific situation vignettes: Evidence of gender-based differences and occupational socialization, *Journal of Business Ethics*, 28 (1), 73-86.
- Tansey, R., Brown, G., Hyman, M. and Dawson, L, Jr. (1994). Personal moral philosophies and the moral judgments of salespeople. *Journal of Personal Selling and Sales Management*, 14 (1), 59-75.

Vermeir, I. and Van Kenhove, P. (2008). Gender differences in double standards, *Journal of Business Ethics*, 81 (2), 281-295.

Weeks, W., Moore, C., McKinney, J, and Longenecker, J. (1999). The effect of gender and career stage on ethical judgment. *Journal of Business Ethics*, 20 (4), 301-313.

# A COMPARISON OF HOME FURNISHINGS EXPENDITURES BY U.S. GENERATIONAL COHORT

Katherine Annette Burnsed, Jessica Strubel and Michael B. Moody

## **Abstract:**

*The majority of U.S. consumers will purchase home furnishings products during their lifetime, since they provide hedonic and utilitarian value. Therefore, it is important for home furnishings retailers to have a better understanding of the key categories purchased by generational cohort (Baby Boomer, Generation X, and Generation Y) for marketing purposes. As such, this study compared U.S. generational cohorts' expenditures of home furnishings. By utilizing the Household Life Cycle Concept as the underlying theoretical foundation for the study, results revealed differences among generational cohorts for durable and nondurable home furnishings and in five of the study's 13 home furnishings' categories.*

**Keywords:** Home furnishings, generational cohort, life stage

**Category:** Research Paper

## **1. INTRODUCTION**

Home furnishings (i.e., household furniture, décor/accessories, and textiles) is a key industry due to its economic impact (a \$278 billion industry) and the fact that it provides consumers with hedonic and utilitarian value (U.S. Bureau of Economic Analysis, 2014). Over the course of a U.S. consumer's lifetime, many home furnishings items will be accumulated and replaced as a result of various intrinsic lifestyle changes and environmental factors. These critical life stage events that trigger home furnishings purchases are oftentimes influenced by a consumer's age (U.S. International Trade Commission, 2001).

Given the variability of generational cohorts in the U.S., this study formally asks whether a

generational cohort effect exists in home furnishings expenditures and, if it does, what differences and similarities are expressed by the key generational consumer groups: Baby Boomers (born between 1946 - 1964), Generation X (born between 1965 - 1980), and Generation Y (born between 1981 - 2000). Although researchers demonstrate great interest in the impact of generational spending habits, at this time, limited empirical and academic research has been conducted on generational consumer expenditures of home furnishings. As such, this study will address this gap in the extant literature by (a) disaggregating home furnishings expenditure data and (b) investigating differences in generational cohort consumption of home furnishings through the use of detailed expenditure data from the 2012 Consumer Expenditure Survey (CE) (U.S. Bureau of Labor Statistics, 2013).

## **Home Furnishings**

Home furnishings are typically classified into two major categories—durable and nondurable.

**Katherine Annette Burnsed**, Ph.D., Department of Retailing, University of South Carolina; 701 Assembly Street, 4005-D Carolina Coliseum, Columbia, SC 29208; Tel. (803) 777-8066; Fax (803) 777-6427; email: kburnsed@mailbox.sc.edu

**Jessica Strubel**, Ph.D., Department of Merchandising & Digital Retailing, University of North Texas, USA

**Michael B. Moody**, M.R., Department of Retailing, University of South Carolina, USA



Durable goods are defined as those that have a significant lifespan (often three years or more) and are highly resistant to wear (InvestorWords, 2016a). Nondurable goods are defined as those that are purchased more frequently, are generally not resistant to wear, and typically have a lifespan of less than three years (InvestorWords, 2016b) (see Table 1 for a complete list of CE classifications and study categories).

**Table 1.** Study's home furnishings category classifications based on type of good.

<i>Type of Good and Category:</i>	<i>Includes the following:</i>
<i>Durable:</i>	
Bedroom Furniture	Mattresses, springs, dressers, beds, chests, and bedroom furniture combinations. Combines codes 120-122.
Dining & Kitchen Furniture	Tables, chairs, etc. Code 110.
Home Office Furniture	All office furniture for home use. Code 150.
Infant Furniture	Cribs, dressers, changing tables, etc. Combines codes 130-131.
Living & Family Room Furniture	Sofas, chairs, tables, wall units, cabinets, shelving, desks, other items not specified elsewhere, and living room combinations. Combines codes 100-103 and 105-106.
Outdoor Furniture	Patio, porch, or outdoor furniture. Combines codes 140-141.
Recreation Room Furniture	Ping-pong tables, pool tables, and other similar recreation room items. Code 104.
<i>Nondurable:</i>	
Accessories	Clocks, lamps, decorative items, slipcovers, and pillows. Combines codes 171, 173, and 205.
Floor Coverings	Room-size rugs and other non-permanent floor coverings. Code 212.
Kitchenware	Dinnerware, non-electronic cookware, glassware, and serving pieces. Combines codes 190-198.
Linens	For use in the bedroom, bathroom, kitchen, and dining room. Combines codes 200-204.
Miscellaneous	Storage and travel items. Combines codes 180-181, 220, and 900.
Window Treatments	Curtains, drapes, blinds, shades, and other window coverings. Combines codes 214-215.

## 2. LITERATURE REVIEW

Historically, home furnishings consumption research has focused on two sectors of the industry: (1) household furniture and (2) household textiles. Research on the consumption patterns of household furniture has indicated the following unique differences: (a) the household head accounts for the bulk of household furniture purchases; (b) although many factors affect consumer demand for household furniture, the consumer's age is a very important indicator because it marks critical life stages that trigger furniture purchases, such as marriage, parenthood, home purchase, and career advancement (increased income); and (c) household furniture consumption involves a much longer time horizon than many other consumer goods because of higher ticket prices and the consideration taken of future earnings and competing expenses (U.S. International Trade Commission, 2001). Additionally, age, existing home sales, new housing starts, income, and unemployment rates have been found to influence the demand for household textiles (U.S. International Trade Commission, 1999).

Further research has indicated that Baby Boomers, Generation X, and Generation Y are not different when it comes to their hedonic and utilitarian attitudes towards household furniture (Burnsed, 2009).

### ***Baby Boomer Cohort***

In 2012, Baby Boomers represented 23.9% of the U.S. population, were aged 48-66, and had a median household income of \$62,519 (Mintel Group Ltd., 2014a). Baby Boomer spending has been estimated to be responsible for half of all consumer expenditures in the U.S. (approximately \$2.3 trillion annually) and they outspend other generations by an estimated \$400 billion each year on consumer goods and services (Mintel Group Ltd., 2014a). Due to their discretionary income, and the fact that they control most of the net worth of American households, many marketers have called the Baby Boomer cohort the most valuable generation (Mintel Group Ltd., 2014a). Their hedonistic nature and discretionary income have made Boomers the primary target of advertising and marketing.

Boomer households typically consist of two or more individuals (three in 10 Boomer households have three or more members) (Mintel Group Ltd., 2014a). Larger households could be attributed to the fact that two-thirds of Boomers are married, many have adult children either still living at home or returning home due to economic and unemployment shifts (Boomerang Effect), and an estimated 40% of Boomers still have children under the age of 18 living at home (Hawkins & Mothersbaugh, 2013; Mintel Group Ltd., 2014a). About seven in 10 are employed, while about half of the oldest Boomers are either retired or not in the labor force (Mintel Group Ltd., 2014a). Baby Boomers who are working full-time and supporting children have different perspectives of their finances and motivations to purchase as compared to retired empty-nest Baby Boomers. In addition to work/retirement and the

Boomerang and Empty Nest Effects, Boomers are experiencing other key life stage events such as becoming grandparents, downsizing the family home, relocating after retirement, and spending more time at home. Altogether, this generation has the money to spend, are not afraid of buying what they want, has a greater comfort with spending on nonessentials, and are not as concerned with always paying the least amount possible (Mintel Group Ltd., 2014a; Wuest, Welkey, Mogab, & Nicols, 2005). Therefore, they have the luxury of focusing on home furnishings. In fact, in 2012, Boomers comprised 45% of total dollars spent on furniture and bedding—spending approximately \$38 million on furniture products (French, 2013).

### ***Generation X Cohort***

Generation X represented 15.7% of the U.S. population, were aged 32-47, and had a median household income of \$63,629 (Mintel Group Ltd., 2014a). Generation X reached adulthood in the midst of economic crises, which they often blame on the Boomer generation (Hawkins & Mothersbaugh, 2013; Lindquist & Sirgy, 2009). Due to this, Gen X is the first American generation to confront issues of “reduced expectations” (Hawkins & Mothersbaugh, 2013, 122). Generation X is not an easy generation to reach because of their cynicism. They are cautious, yet pragmatic, shoppers who lack brand loyalty yet possess a distinct sophistication about products and shopping (Evans, 2005; Hawkins & Mothersbaugh, 2013; Wuest et al., 2008). They want products designed specifically for their tastes and lifestyles (Hawkins & Mothersbaugh, 2013).

Nearly two thirds of Gen Xers are homeowners, as well as married, making this generation an attractive market for home improvement products including home furnishings (Miller, 2011; Mintel Group Ltd., 2011). Gen Xers are family-oriented (71% of households have children younger than 18 living at home) and focus on balancing work and family (Miller,

2011). The resulting household size is an average of 3.3 persons per home, which is substantially larger than the national average of 2.5 (Miller, 2011). In accordance with their family-orientation, Gen X accounted for 37% of all purchases of youth bedroom furniture buys in 2012 (French, 2013).

Generation X consumers spend their disposable income wisely, and they are more realistic about what furniture works for a growing family ("Life Stages," 2008; Hodnett, 2013). According to French (2013), Gen X comprised 24% of all furniture and bedding buys in 2012. This is not surprising, since many Gen Xers are upgrading from their starter homes, remodeling kids' rooms, accommodating new technology (especially entertainment systems), and wearing out starter furniture ("Life Stages," 2008). Additionally, Gen X women watch the most home improvement media and are more likely than their male counterparts to initiate home improvement projects (Hawkins & Mothersbaugh, 2013).

### ***Generation Y Cohort***

In 2012, Generation Y represented 24.7% of the U.S. population and were aged 12-31 (Intel Group Ltd., 2014b). It is important to note; however, that the current study will only focus on Gen Yers aged 18-31. Younger Millennials' median household income (\$30,604) was significantly lower than that of older Millennials (\$51,381), because they were in different stages of education and career (Intel Group Ltd., 2014b). As a result of a second baby boom, Millennials (Gen Y) are one of the largest, most diverse (i.e., more racially and ethnically diverse), and most influential contemporary adult populations (Hawkins & Mothersbaugh, 2013; Magid Generational Strategies, 2014; Pew Research Center, 2014).

Because of the Great Recession of the 21<sup>st</sup> century, younger Millennials have been plagued by high unemployment rates (Hawkins & Mothersbaugh, 2013; Pew Research Center,

2014). This has resulted in many of them moving back into their parents' homes (Boomerang Effect); however, they remain fairly optimistic about their financial futures. The marketplace is also optimistic about the future of these young adults. It is expected that by 2015, Millennials will have \$2.45 trillion in spending power, making them an important consumer group (Oracle Financial Services, 2010). However, traditional marketing channels need to be seamlessly integrated with the online platform to effectively reach Millennials, who are not only digitally connected but also more receptive to new ideas. It is also important for businesses to note that Millennials tend to be brand loyal and place great importance on brand appeal; thereby, affording them desired recognition from their peers (Evans, 2005; Wuest et al., 2008).

Because Generation Y spans 18 years, this generational cohort was experiencing various major life stage benchmarks in 2012 and they continue to be in a period of firsts and significant changes. For example, many Millennials are starting to live independent of their parents, they are graduating from college, getting their first jobs, making their first significant purchases (e.g., homes), getting married, and starting a family (Deloitte, 2015; "Life Stages," 2008; Hodnett, 2013; Intel Group Ltd., 2014b). Each of these life stages trigger the need and/or desire for home furnishings purchases. Because many are just starting out and tend to be more individualistic, Gen Y consumers are looking for home furnishings that are affordable and reflect their personal tastes ("Life Stages," 2008). In 2012, Millennials accounted for 12% of the total dollars spent on furniture and bedding (\$11 million) (French, 2014). As with their other purchases, Gen Y feels comfortable making purchases online—78% have purchased home furnishings online (French, 2013).

### **Framework and Hypothesis Development Theoretical**

The purchase of home furnishings has been directly linked to life stage events of consumers ("Life Stages," 2008; Mintel Group Ltd., 2005). Life stage events are direct life status changes because they are unique to the type of change, they are experienced by practically all households undergoing that change, and the nature and timing of such events are associated with patterns of expenditures by consumers (Andreasen, 1984). The predictable stages; therefore, can be investigated via generational cohorts, since major life stage events are specific to individual generations when fixed in time (i.e., they are experienced by practically all consumer units undergoing that change). Because of the changing identity of the average U.S. family that now includes homosexual couples, D.I.N.K.'s (Dual Income No Kids), and other non-traditional family formats, this study's focus is on the household/consumer unit (CU). As such, the theoretical foundation for the study utilizes Engel, Blackwell, and Miniard's (1993) *Household Life Cycle Concept*; whereby, households/consumer units (persons living together and sharing their financial budget independent from marriage license and offspring) pass through a progression of stages which impact purchasing behavior and consumption of goods and services. Based on the life stage differences between the generational cohorts and a modified version of Engel, Blackwell, and Miniard's (1993) *Household Life Cycle Concept*, the following was hypothesized:

*H<sub>1</sub>: Average aggregate CU expenditures of durable and nondurable home furnishings demonstrate an overall generational cohort effect.*

*H<sub>2</sub>: Average aggregate CU expenditures of durable and nondurable home furnishings demonstrate generational cohort differences.*

*H<sub>3</sub>: Average aggregate CU expenditures of the 13 individual home furnishings categories demonstrate a generational cohort effect.*

*H<sub>4</sub>: Average aggregate CU expenditures of the 13 individual home furnishings categories demonstrate generational cohort differences.*

### **3. METHODOLOGY**

#### **Data Source and Study Sample**

Study data were extracted from the quarterly interview segment of the 2012 CE, and included only CUs in which both age had been designated by the CU head (for generational cohort classification) and expenditures had been recorded in both the durable and nondurable categories of home furnishings (U.S. Bureau of Labor Statistics, 2013). The CE measures spending by consumer units (CU) rather than family households. As defined by the CE, a CU comprises either: (1) all members of a particular household who are related by blood, marriage, adoption, or other legal arrangements; (2) a person living alone, sharing a household with others, or living as a roomer in a private home, lodging house, or in permanent living quarters in a hotel or motel, but who is financially independent; or (3) two or more persons living together who use their income to make joint expenditure decisions (U.S. Bureau of Labor Statistics, 2013). The CE was selected for this study because it is the only Federal U.S. survey that provides information on the complete range of American consumers' expenditures and incomes, as well as the characteristics of those consumers (U.S. Bureau of Labor Statistics, 2013).

After data were extracted from the 2012 CE, normality was assessed via boxplots, skewness and kurtosis measurements, and normality tests. To approximate a normal distribution more closely, consumer units with extreme outliers in either durable or nondurable home furnishings were eliminated from the data set. The remaining data used for analysis fell within two

standard deviations from the means, capturing approximately 95% of the study's observations. Altogether, yielding a total of 785 CUs: 289 (36.82%) Baby Boomer, 191 (24.33%) Generation X, and 305 (38.85%) Generation Y CUs. As a check for sample representativeness, the adjusted sample was compared to actual 2012 U.S. population data. Although not reflecting the general U.S. population precisely, the sample was deemed a satisfactory representation since all three generational cohorts were slightly over-represented.

### ***Home Furnishings Expenditure Classifications***

Although the 2012 CE divided home furnishings expenditures into consumer purchases (Section 8, Part A) and consumer rentals, leases, or repairs (Section 8, Part B), only expenditures from the consumer purchases section that were intended for use by the CU were included in the study's analyses (U.S. Bureau of Labor Statistics, 2013). The original 40 home furnishings CE classifications were then collapsed into 13 categories for analysis purposes based on familiar consumer meta-categories: (1) accessories; (2) bedroom furniture; (3) dining and kitchen furniture; (4) floor coverings; (5) home office furniture; (6) infant furniture; (7) kitchenware; (8) linens; (9) living and family room furniture; (10) miscellaneous; (11) outdoor furniture; (12) recreation room furniture; and (13) window treatments (see Table 1).

To explore the question of an overall generational cohort effect on home furnishings expenditures, annual expenditures (summed quarters) for the 13 furnishings categories were sorted into either durable or nondurable expenditures. Ten of the study's home furnishings categories fit clearly into either the durable (i.e., sofas, chairs, and tables) or nondurable (i.e., accessories and linens) classification, while three categories demonstrated both durable and nondurable qualities. Therefore, the three categories (mattresses and springs [CE category 120], rugs

and other non-permanent floor coverings [CE category 212], and window treatments [CE category 214-215]) were assessed based on their repurchase profile by the average consumer unit. After review, mattresses were classified as a durable good, because of their infrequent repurchase rate (often eight to 10 years). Floor coverings and window treatments were classified as nondurable goods due to a more frequent repurchase rate (often one to three years).

### ***Analysis Procedures***

In order to test for the presence of an overall generational cohort effect on durable and nondurable home furnishings expenditures (hypothesis one), MANOVA was performed. To address the research question of whether average aggregate CU home furnishings expenditures (durables and nondurables) differed across generational cohorts (hypothesis two), a profile analysis of repeated measures, or the multivariate approach to repeated measures, was used. Additionally, post-hoc pairwise comparisons using Tukey's HSD procedure for unequal sample sizes were conducted on the main effects to test for home furnishings expenditure mean differences (durable and nondurable) among the three generational cohort groups. In order to test hypothesis three, ANOVAs were conducted to find generational cohort effects on mean expenditures for the 13 individual home furnishings categories. Post-hoc pairwise comparisons using Tukey's HSD procedure for unequal sample sizes were then conducted on the main effects to test for home furnishings expenditure mean differences between generational cohorts for the 13 individual home furnishings categories (hypothesis four). The dependent variables for testing hypotheses one and two were the aggregate CU durable and nondurable home furnishings expenditures (measured in U.S. dollars per CU), while aggregate CU category expenditures were used

for hypotheses three and four. All hypotheses utilized generational cohort CUs as the

independent, categorical variable. Finally, all significance levels for were set at  $\alpha \leq .05$ .

#### 4. RESULTS AND DISCUSSION

##### *Hypothesis One and Two*

MANOVA testing for an overall generational cohort effect provided strong support for hypothesis one ( $\Lambda = 0.9771$ ,  $F(4, 1562) = 4.55$ ,  $p = .0012$ ) relative to both durable and nondurable home furnishings expenditures. Significant generational cohort effects were found for both durable ( $F(2, 782) = 6.91$ ,  $p = .0011$ ) and nondurable ( $F(2, 782) = 4.63$ ,  $p = .0100$ ) home furnishings expenditures.

The Wilks' Lambda criterion p-value ( $\leq .05$ ) provided statistical evidence of interaction (parallelism) between home furnishings expenditures (durable and nondurable) and generational cohort (see Table 2). The test for

differences among groups (equal levels) found differences ( $p \leq .05$ ) among generational cohorts when durable and nondurable home furnishings expenditures were averaged, providing strong statistical evidence of a generational cohort effect (between-subjects effects). Therefore, hypothesis two was supported and thereby, providing further support for hypothesis one. The test for a goods category effect (flatness) found that home furnishings expenditure means, when averaged across generational cohort, indicated a goods category effect (durable and nondurable) based on the Wilks' Lambda criterion p-value ( $\leq .05$ ).

**Table 2.** Profile analysis: Testing for differences among generational cohorts ( $H_2$ ).

Source	df	Sum of Squares	Mean Square	$\Lambda$	F	p-value
<i>Between-Subjects Effects:</i>						
Generational Cohort (Testing for Overall Difference Among Generational Cohorts)	2	6723338.3	3361669.2		8.36*	0.0003
Error	782	314564817.5	402256.8			
<i>Within-Subjects Effects:</i>						
Goods Category (Testing for a Goods Category Effect)	1	68920666.0	68920666.0	0.7715	231.60*	<0.0001
Goods Category * Generational Cohort (Testing for Interaction)	2	2718456.7	1359228.3	0.9885	4.57*	0.0107
Error	782	232710285.6	297583.5			

Note: \*Significant:  $p \leq .05$ .

Post-hoc pairwise comparisons using Tukey's HSD procedure provided further support for durable and nondurable mean expenditure differences among generational cohorts (hypothesis two). Differences were found among Generation X and Generation Y for both durable and nondurable home furnishings mean expenditures (see Table 3). Altogether, Generation Y CUs had lower durable and nondurable home furnishings mean

expenditures as compared to Baby Boomer and Generation X CUs. On average, Generation Y CUs durable mean expenditures (\$502.06) were \$107.71 less than Baby Boomer CUs (\$609.77) and \$276.25 less than Generation X CUs (\$778.31). For nondurable mean expenditures, Generation Y CUs (\$168.91) were \$37.05 less than Baby Boomer CUs (205.96) and \$61.62 less than Generation X CUs (\$230.53).



**Table 3.** Mean vectors: Testing for differences among generational cohorts ( $H_2$ ).

<i>Generational Cohort</i>	<i>Goods Category</i>	<i>n</i>	<i>Mean</i>	<i>Standard Error</i>	<i>Standard Deviation</i>
Overall (All CUs)	Durable	785	\$608.93	\$28.95	\$811.17
	Nondurable	785	\$197.54	\$8.15	\$228.25
Baby Boomer CUs	Durable	289	\$609.77	\$47.67	\$810.35
	Nondurable	289	\$205.96	\$13.96	\$237.28
Generation X CUs	Durable	191	\$778.31 <sup>1</sup>	\$74.18	\$1,025.12
	Nondurable	191	\$230.53 <sup>2</sup>	\$19.47	\$269.10
Generation Y CUs	Durable	305	\$502.06 <sup>1</sup>	\$35.69	\$623.34
	Nondurable	305	\$168.91 <sup>2</sup>	\$10.59	\$184.89

Note: CU = consumer unit. Mean expenditures having the same superscript number in the mean column represent generational cohort effects that are significantly different at  $\alpha \leq .05$  (Tukey HSD procedure).

#### **Hypothesis Three and Four**

ANOVA testing on the 13 individual home furnishings categories found significant ( $p \leq .05$ ) generational cohort effects (hypothesis three) for five of the 13 categories: accessories, floor coverings, living and family room furniture, outdoor furniture, and window treatments (see Table 4). Marginal significance ( $p$  is between .05 and .10) was found for bedroom furniture and linens. Pairwise comparisons using Tukey's HSD, for testing hypothesis four, provided evidence of generational cohort expenditure mean differences in the accessories, floor coverings, living and family room furniture, outdoor furniture, and window treatment categories (see Table 5). Based on an  $\alpha \leq .05$ , Generation Y CUs differed from Baby Boomer and Generation X CUs in the accessories, floor coverings, living and family room furniture, and outdoor furniture

categories. Additionally, Generation Y CUs had significant mean expenditure differences from Generation X CUs in the window treatment category. Although marginal significance ( $p$  is between .05 and .10) of an overall generational cohort effect for bedroom furniture and linens was found for purchasing CUs, no significant mean differences were exhibited among the generational cohort CUs. Altogether, dining and kitchen furniture, home office furniture, infant furniture, kitchenware, miscellaneous, and recreation room furniture were the only categories to not provide evidence of a generational cohort effect whatsoever. Additionally, the majority of significant results for mean expenditure differences of home furnishings were found between Generation Y CUs and their generational cohort counterparts (Baby Boomer and Generation X CUs).

**Table 4.** Generational cohort effects of mean expenditures for the 13 categories of home furnishings ( $H_3$ ).

Category	n	df	F	p-value
Accessories	779	2, 777	6.90*	0.0011
Bedroom Furniture	627	2, 625	2.36**	0.0955
Dining & Kitchen Furniture	206	2, 204	0.12	0.8901
Floor Coverings	250	2, 248	4.79*	0.0091
Home Office Furniture	103	2, 101	0.37	0.6938
Infant Furniture	254	2, 252	1.88	0.1553
Kitchenware	690	2, 688	0.07	0.9319
Linens	1,073	2, 1071	2.28**	0.1027
Living & Family Room Furniture	856	2, 854	12.19*	<0.0001
Miscellaneous	203	2, 201	0.39	0.6784
Outdoor Furniture	412	2, 410	5.43*	0.0047
Recreation Room Furniture	10	2, 8	0.57	0.5865
Window Treatments	344	2, 342	6.36*	0.0019

Note: \*Significant:  $p \leq .05$ ; \*\*Marginally significant:  $p$  is between .05 and .10.

**Table 5.** Mean expenditures and statistically significant mean expenditure differences for the 13 categories of home furnishings ( $H_4$ ).

Category	Generational Cohort		
	Baby Boomer CUs	Generation X CUs	Generation Y CUs
Accessories	\$133.35 <sup>a</sup>	\$133.43 <sup>b</sup>	\$83.16 <sup>a,b</sup>
Bedroom Furniture	\$730.09	\$591.82	\$605.71
Dining & Kitchen Furniture	\$377.67	\$404.34	\$366.56
Floor Coverings	\$123.80 <sup>a</sup>	\$127.16 <sup>b</sup>	\$63.07 <sup>a,b</sup>
Home Office Furniture	\$138.32	\$127.76	\$158.79
Infant Furniture	\$139.42	\$194.58	\$155.15
Kitchenware	\$64.35	\$66.11	\$63.42
Linens	\$83.34	\$92.46	\$80.24
Living & Family Room Furniture	\$564.15 <sup>a</sup>	\$681.40 <sup>b</sup>	\$381.69 <sup>a,b</sup>
Miscellaneous	\$76.80	\$66.36	\$73.12
Outdoor Furniture	\$167.99 <sup>a</sup>	\$171.65 <sup>b</sup>	\$106.30 <sup>a,b</sup>
Recreation Room Furniture	\$352.00	\$377.50	\$132.00
Window Treatments	\$96.67	\$144.54 <sup>a</sup>	\$69.64 <sup>a</sup>

Note: CU = consumer unit. Pairwise comparisons are only across generational cohorts. Mean expenditures having the same superscript letter in each row are significantly different at  $\alpha \leq .05$  (Tukey HSD procedure).

Based on the means for the 13 home furnishings categories, Generation Y CUs on average spent less than their generational cohort counterparts in nine of the 13 home furnishings categories: accessories, dining and kitchen furniture, floor coverings, kitchenware, linens, living and family room furniture, outdoor furniture, recreation room furniture, and window treatments (see Table 5). On average, Generation Y CUs

(\$158.79) spent more than Baby Boomer (\$138.32) and Generation X (\$127.76) CUs in the home office furniture category. Although Generation Y CUs spent less than Baby Boomer CUs in the bedroom furniture and miscellaneous categories, on average they spent more than Generation X CUs. Additionally, Generation Y CUs (\$155.15) spent on average more than Baby Boomer CUs (\$139.42) in the infant furniture

category and a little less than Generation X CUs cohort revealed the most and least purchased (\$194.58). Finally, purchase frequencies for the product categories (see Table 6).  
13 home furnishings categories by generational

**Table 6.** Purchase frequencies for the 13 categories of home furnishings by generational cohort.

<i>Baby Boomer CUs</i>			<i>Generation X CUs</i>			<i>Generation Y CUs</i>		
<i>Category</i>	<i>n</i>	<i>%</i>	<i>Category</i>	<i>n</i>	<i>%</i>	<i>Category</i>	<i>n</i>	<i>%</i>
Linens	429	18.58	Linens	271	18.90	Linens	374	18.01
L&F Room Furniture	334	14.47	L&F Room Furniture	207	14.44	L&F Room Furniture	316	15.21
Accessories	318	13.77	Accessories	191	13.32	Accessories	271	13.05
Kitchenware	267	11.56	Kitchenware	174	12.13	Kitchenware	250	12.04
Bedroom Furniture	229	9.92	Bedroom Furniture	158	11.02	Bedroom Furniture	241	11.60
Outdoor Furniture	196	8.49	Outdoor Furniture	106	7.39	Outdoor Furniture	129	6.21
Window Treatments	129	5.59	Window Treatments	87	6.07	Window Treatments	123	5.92
Floor Coverings	108	4.68	Floor Coverings	57	3.97	Outdoor Furniture	111	5.34
Miscellaneous	91	3.94	Miscellaneous	53	3.70	Floor Coverings	86	4.14
Infant Furniture	89	3.85	D&K Furniture	47	3.28	D&K Furniture	82	3.95
D&K Furniture	78	3.38	Infant Furniture	43	3.00	Miscellaneous	60	2.89
Home Office Furniture	37	1.60	Home Office Furniture	38	2.65	Home Office Furniture	29	1.40
Rec. Room Furniture	4	0.17	Rec. Room Furniture	2	0.14	Rec. Room Furniture	5	0.24

Note: CU = consumer unit; L&F = Living & Family; D&K = Dining & Kitchen; Rec. = Recreation.

## 5. CONCLUSIONS

### Summary

This study investigated the possible influence of a generational cohort effect on U.S. consumer unit home furnishings expenditures. The purpose and overall objectives of the study were to contribute to the home furnishings and consumer behavior literature by disaggregating home furnishings expenditure data and investigating differences in generational cohort consumption as they relate to home furnishings. In doing so, four hypotheses were formulated and tested.

Hypothesis one (average aggregate CU expenditures of durable and nondurable home furnishings demonstrate an overall generational cohort effect) found significant generational cohort effects for both durable and nondurable home furnishings expenditures. Hypothesis two (average aggregate CU expenditures of durable and nondurable home furnishings demonstrate generational cohort differences) further supported hypothesis one by providing statistical evidence of durable and nondurable mean

expenditure differences among the three generational cohorts. Altogether, Generation Y CU mean expenditures for durable and nondurable home furnishings were less than Generation X and Baby Boomer CUs. These findings could be attributed to the fact that many Generation Y consumers were between the ages of 18-35 in 2012 and were either (1) attending college and living in a dorm; therefore, the necessity of home furnishings is limited; (2) attending college and living in a "shared" residence (i.e., a roommate in a house or apartment); therefore, the responsibility of furnishing the house or apartment is divided among the roommates and no "one" roommate is responsible for furnishing the entire residence; or (3) living in a non-permanent dwelling (e.g., renting a house or apartment); therefore, they may be delaying their home furnishings purchases for when they settle into a more permanent location (i.e., become less transient). A breakdown of the study participant's housing tenure may further

justify these inferences, because results revealed that 75% of Generation Y CUs rented and only 25% owned, while 35% of Generation X CUs rented and 65% owned, and 19.5% of Baby Boomer CUs rented and 80.5% owned. Additionally, many Generation Y CUs (due to their age), as compared to their generational cohort counterparts, were either graduating from high school or college, establishing their independence from the parents, or trying to build their careers; therefore, their average annual income was not as high as Generation X and Baby Boomer CUs. A breakdown of the study participant's average annual incomes could possibly justify these inferences due to the following: 30% of Generation Y CUs earned \$70,000<sup>+</sup> and 70% less than \$69,999; 58.3% of Generation X CUs earned \$70,000<sup>+</sup> and 41.7% less than \$69,999; and 57.4% of Baby Boomer CUs earned \$70,000<sup>+</sup> and 42.6% less than \$69,999. Altogether, Generation Y CUs have lower levels of discretionary income; therefore, limiting their ability to purchase home furnishings. Finally, current U.S. trends have seen many Generation Yers prolonging marriage and children in hopes of building or advancing their careers and enjoying the "single life", having fewer children, and having a smaller number of people per household. Due to these trends, all of which impact home furnishings purchases, it is not surprising that Generation Y CUs spent less on durable and nondurable home furnishings than that of Generation X and Baby Boomer CUs.

Hypothesis three (average aggregate CU expenditures of the 13 individual home furnishings categories demonstrate a generational cohort effect) revealed significant generational cohort effects and hypothesis four (average aggregate CU expenditures of the 13 individual home furnishings categories demonstrate generational cohort differences) provided statistical evidence of generational cohort expenditure mean differences in five (accessories, floor coverings, living and family

room furniture, outdoor furniture, and window treatments) of the 13 categories. Altogether, Generation Y CUs on average spent less than Generation X and Baby Boomer CUs. Again, this could be attributed to the fact that Generation Y CUs had lower average annual incomes, the majority rented their dwellings, and/or they were delaying purchasing "quality", higher-priced home furnishings until they become more established in their careers or when they are less transient. Lower levels of spending for outdoor furniture and window treatments could be due to the fact that 75% of Generation Y CUs rented their dwelling and many rental units have limited or no outdoor spaces (e.g., patios or balconies) for personal use and/or come equipped with blinds; therefore, the need for these product categories is either nonexistent or limited.

The final results of the study calculated frequencies of purchase for the 13 home furnishings categories by generational cohort CU. The top five categories (linens, living and family room furniture, accessories, kitchenware, and bedroom furniture) were the same for all three generational cohorts. The fact that linens ranked first could be because they are nondurable, are used on a daily basis, have the tendency to "wear" and show soiling faster, and are relatively inexpensive to replace. Living and family room furniture's second place purchase frequency may be attributed to the fact that this is the furniture that family, friends, and guests see first; therefore, CUs may have focused their attention on this category in order to make it the most attractive room in the home and/or "dress" their room in the image that they want to convey to others. Additionally, this furniture is used on a daily basis; therefore, has the tendency to show "wear" faster. Accessories (third) and kitchenware (fourth) are both nondurable and on average considered smaller ticket items that need more frequent replacement. Furthermore, accessories allow CUs to update the look of their home without investing a lot of "decision-making" time or

money. Bedroom furniture, the fifth most purchased category by all three generational cohorts, could signify the need to satisfy oneself after the need to project a particular image to guests (i.e., living and family room furniture). The next six categories (outdoor furniture, window treatments, floor coverings, miscellaneous, infant furniture, and dining and kitchen furniture) experienced differences in purchase frequencies, which could be attributed to durability or lack thereof, income, housing tenure, and/or number of children in the household. Finally, home office furniture (12<sup>th</sup>) and recreation room furniture (13<sup>th</sup>) were the least purchased product categories of home furnishings. With the influx of portable technologies (e.g., laptop computer, tablets, and smartphones) that can be used/accessed anywhere in the home, a designated location/room is not as pertinent as it once was; therefore, home office furniture may not be a priority to the investigated generational cohort CUs. Since this study utilized 2012 CE data, which captured a U.S. economic downturn, recreation room furniture may have not been a priority for the three key generational cohorts since it ranked last in purchase frequency.

#### *Implications*

Although the findings of this study are market specific, they have important implications for the home furnishings industry. Overall, this study provides retailers and marketers with a greater understanding of the three key U.S. generational cohorts' differences, similarities, and purchase frequencies of durable and nondurable home furnishings. Moreover, it allows retailers and marketers to tailor their product assortments and advertising to individual generational cohorts; thereby, not accepting or implementing a "one size fits all" approach. Based on regional generational cohort

populations in the area (e.g., predominately college towns/cities or retirement communities), retailers and marketers could target individual generations by offering and promoting specific product categories of interest and through special financing (e.g., one year-no payments-no interest to areas that primarily consist of Generation Y and Generation X CUs, since many are in the process of establishing independence, building or advancing their careers, and/or starting families).

#### ***Limitations and Future Research***

This study utilized data from the 2012 CE (which at the time was the most recent CE data available); therefore, the researchers relied upon the accuracy of the individual CUs to record all home furnishings expenditures and properly self-identify the CU head's age. Secondly, this study focused on the CU head's age (which generational cohort was classified by); therefore, it did not take into account the spouse's age or that of the other household members. Although this study did not investigate income and housing tenure effects, it would be of interest to examine how these variables impact generational cohort home furnishings expenditures since they appear to have an overarching influence. Additional variables of interest for future studies would be to see how marital status, dwelling square footage, number of children in the household, whether or not the person was attending college, and the number of persons living in the household influences home furnishings expenditures. Finally, since the U.S. was undergoing and climbing out of an economic recession in 2012, it would be beneficial to compare these results to those of a later date (year) when the U.S. is not experiencing an economic hardship.



## REFERENCES

- Andreasen, A.R. (1984). Life status changes and changes in consumer preferences and satisfaction. *Journal of Consumer Research*, 11, 784-794.
- Burnsed, K.A. (2009). *Attitudes toward home furnishings case goods: An investigation of motivations and values relative to product choice* (Doctoral Dissertation). University of North Carolina at Greensboro, USA.
- Deloitte. (2015). *Mind the gaps: The 2015 Deloitte Millennial survey*. Retrieved from [www2.deloitte.com/content/dam/Deloitte/global/Documents/About-Deloitte/gx-wef-2015-millennial-survey-executivesummary.pdf](http://www2.deloitte.com/content/dam/Deloitte/global/Documents/About-Deloitte/gx-wef-2015-millennial-survey-executivesummary.pdf)
- Engel, J.F., Blackwell, R.D., & Miniard, P.W. (1993). *Consumer behavior*. Chicago, IL: Dryden.
- Evans, G. (2005). Industry needs to understand Gens X & Y. *Furniture Today*, 29(48), 22.
- French, D. (2013). Boomers account for 45% of spending. *Furniture Today*, 37(34), 6.
- French, D. (2014). Millennials' buying power will only increase. *Furniture Today*, 38(2), 49.
- Hawkins, D.I. & Mothersbaugh, D.L. (2013). *Consumer behavior: Building marketing strategies*. New York, NY: McGraw Hill.
- Hodnett, C.W. (2013). Contemporary's new generation. *Furniture Today*, 38(12), 1.
- InvestorWords. (2016a). Durable goods. Retrieved from [http://www.investorwords.com/1600/durable\\_goods.html](http://www.investorwords.com/1600/durable_goods.html)
- InvestorWords. (2016b). Nondurable good. Retrieved from [http://www.investorwords.com/6597/non\\_durable\\_good.html](http://www.investorwords.com/6597/non_durable_good.html)
- Life stages dictate buying habits. (2008). *Furniture Today*, 33(13), 52.
- Lindquist, J.D. & Sirgy, M.J. (2009). *Shopper, buyer, and consumer behavior: Theory, marketing applications and public policy implications*. Cincinnati, OH: Cengage Learning.
- Magid Generational Strategies. (2014). *The first generation of the Twenty-First Century: An introduction to the Pluralist Generation*. Retrieved from <http://magid.com/sites/default/files/pdg/MagidPluralistGenerationWhitepaper.pdf>
- Miller, J.D. (2011). Active, balanced, and happy: These young Americans are not bowling alone. *The Generation X Report: A Quarterly Research Report from the Longitudinal Study of American Youth*, 1(1), 1-8.
- Mintel Group Ltd. (2005). *Furniture-US*. Retrieved from [academic.mintel.com](http://academic.mintel.com)
- Mintel Group Ltd. (2011). *Marketing to Gen X*. Retrieved from [academic.mintel.com](http://academic.mintel.com)
- Mintel Group Ltd. (2014a). *Marketing to Baby Boomers*. Retrieved from [academic.mintel.com](http://academic.mintel.com)
- Mintel Group Ltd. (2014b). *Marketing to Millennials*. Retrieved from [academic.mintel.com](http://academic.mintel.com)
- Oracle Financial Services. (2010). *Survey report on Gen-Y banking by Efma and Oracle Financial Services*. Retrieved from [www.oracle.com/us/industries/financial-services/gen-y-survey-report-165297.pdf](http://www.oracle.com/us/industries/financial-services/gen-y-survey-report-165297.pdf)
- Pew Research Center. (2014). *Millennials in adulthood: Detached from institutions, networked with friends*. Retrieved from [www.pewsocialtrends.org/2014/03/07/millennials-in-adulthood/](http://www.pewsocialtrends.org/2014/03/07/millennials-in-adulthood/)
- U.S. Bureau of Economic Analysis. (2014). *Real personal consumption expenditures by function, chained dollars*. Retrieved from [www.bea.gov/iTable/iTable.cfm?ReqID=9&step=1#reqid=9&step=3&isuri=1&909=75](http://www.bea.gov/iTable/iTable.cfm?ReqID=9&step=1#reqid=9&step=3&isuri=1&909=75)
- U.S. Bureau of Labor Statistics. (2013). *Consumer Expenditure Survey: 2012*. Retrieved from [www.bls.gov/cex/](http://www.bls.gov/cex/)



U.S. International Trade Commission. (1999). *Industry and trade summary: Home textiles* (Publication No. 3170). Washington, DC: Government Printing Office.

U.S. International Trade Commission. (2001). *Industry and trade summary: Furniture and*

*motor vehicle seats* (Publication No. 3382). Washington, DC: Government Printing Office.

Wuest, B., Welkey, S., Mogab, J., & Nicols, K. (2008). Exploring consumer shopping preferences: Three generations. *Journal of Family & Consumer Sciences*, 100(1), 31-37.



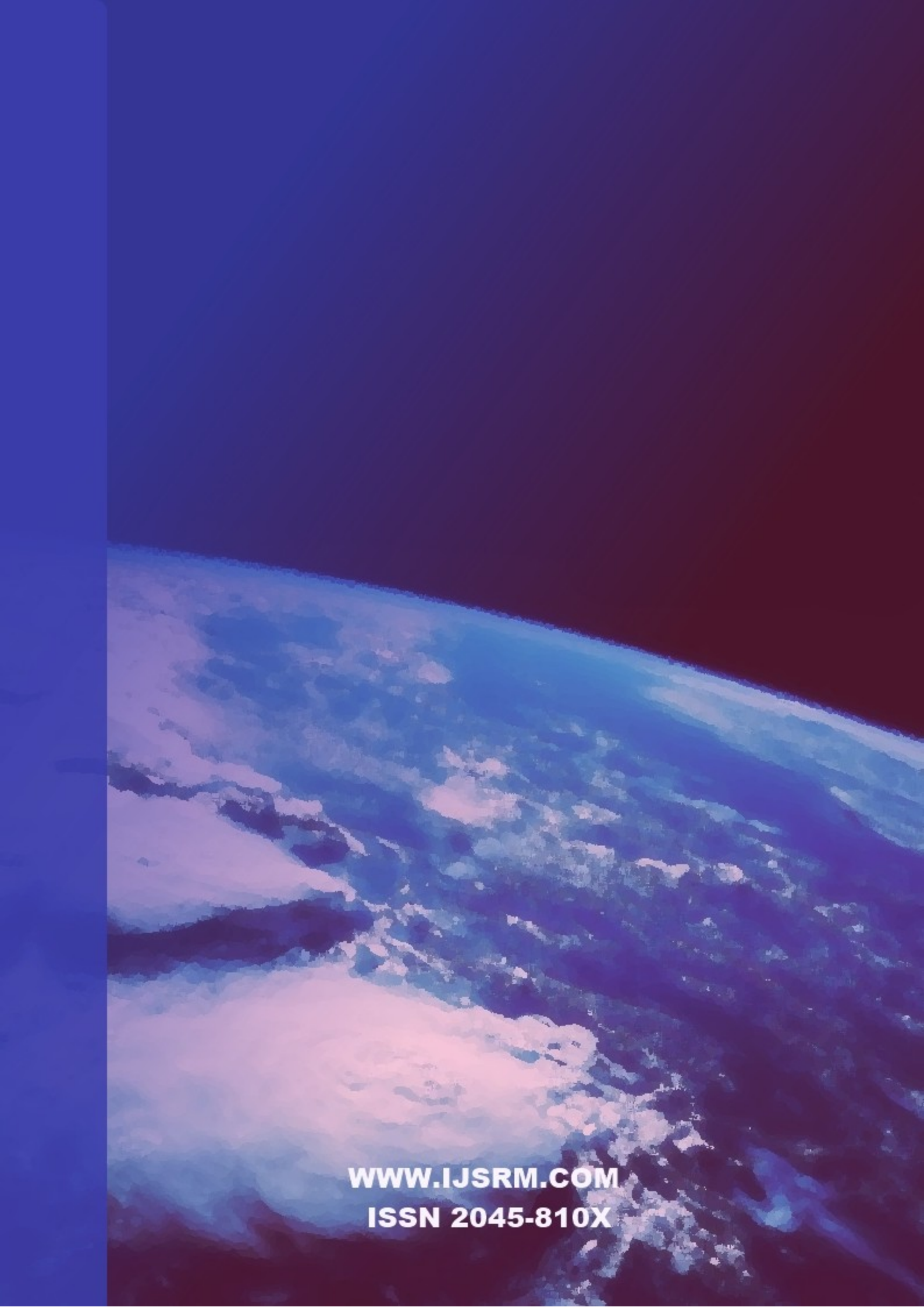

**[WWW.IJSRM.COM](http://WWW.IJSRM.COM)**  
**ISSN 2045-810X**